

# RISE OF RENEWABLES IN CITIES

ENERGY SOLUTIONS  
FOR THE URBAN FUTURE



Supported by:



Federal Ministry  
for the Environment, Nature Conservation  
and Nuclear Safety

Unless otherwise stated, material in this publication may be freely used, shared, copied, reproduced, printed and/or stored, provided that appropriate acknowledgement is given of IRENA as the source and copyright holder. Material in this publication that is attributed to third parties may be subject to separate terms of use and restrictions, and appropriate permissions from these third parties may need to be secured before any use of such material.

**Citation:** IRENA (2020), *Rise of renewables in cities: Energy solutions for the urban future*, International Renewable Energy Agency, Abu Dhabi.

ISBN 978-92-9260-271-0

---

## About IRENA

The International Renewable Energy Agency (IRENA) serves as the principal platform for international co-operation, a centre of excellence, a repository of policy, technology, resource and financial knowledge, and a driver of action on the ground to advance the transformation of the global energy system. An intergovernmental organisation established in 2011, IRENA promotes the widespread adoption and sustainable use of all forms of renewable energy, including bioenergy, geothermal, hydropower, ocean, solar and wind energy, in the pursuit of sustainable development, energy access, energy security and low-carbon economic growth and prosperity. [www.irena.org](http://www.irena.org)

---

## IKI support

This report forms part of the Energy Solutions for Cities of the Future project, which is supported by the International Climate Initiative (IKI). The German Federal Ministry for the Environment, Nature Conservation and Nuclear Safety (BMU) supports this initiative on the basis of a decision adopted by the German Bundestag.

## Acknowledgements

IRENA would like to express sincere appreciation to the experts who reviewed the report. Insightful comments and constructive suggestions were provided by Anjali Mahendra (World Resources Institute), Gerhard Stryi-Hipp (Fraunhofer Institute for Solar Energy Systems), Haukur Harðarson (ArcticGreen Energy Corporation), Helen Carlström (E.ON), Li Zhu (APEC Sustainable Energy Center), Sven Teske (University of Technology Sydney), Toby Couture (E3 Analytics), Vincent Kitio (UN-Habitat), Weimin Xi and Changxia Zhu (City and Energy Research Institute of State Grid Corporation of China) and Zhipeng Liang (National Energy Administration of China).

IRENA colleagues Arina Anisie, Asami Miketa, Celia García-Baños, Elena Ocenic, Francisco Boshell, Jinlei Feng, Luis Janeiro, Michael Renner and Prasoon Agarwal provided valuable reviews and input.

Helpful feedback also came from Paul Komor, Neil MacDonald and Elizabeth Press. Lisa Mastny edited the report.

IRENA is grateful for the support of Germany's IKI project in producing this publication.

**Contributing authors:** This report was prepared, under the guidance of Dolf Gielen, by the sustainable urban energy team at IRENA's Innovation and Technology Centre (IITC). It was authored by Yong Chen, Enzia Schnyder and Jennifer Potter (IRENA) and Mashael Yazdanie (Empa) with additional contributions and support from Julien Marquant (IRENA), Dorine Hugenholtz (IRENA) and Alina Gilmanova (Chinese Academy of Sciences).

For further information or to provide feedback, go to [publications@irena.org](mailto:publications@irena.org)

Download from [www.irena.org/publications](http://www.irena.org/publications)

---

## Disclaimer

This publication and the material herein are provided "as is". All reasonable precautions have been taken by IRENA to verify the reliability of the material in this publication. However, neither IRENA nor any of its officials, agents, data or other third-party content providers provides a warranty of any kind, either expressed or implied, and they accept no responsibility or liability for any consequence of use of the publication or material herein.

The information contained herein does not necessarily represent the views of all Members of IRENA. The mention of specific companies or certain projects or products does not imply that they are endorsed or recommended by IRENA in preference to others of a similar nature that are not mentioned. The designations employed, and the presentation of material herein, do not imply the expression of any opinion on the part of IRENA concerning the legal status of any region, country, territory, city or area or of its authorities, or concerning the delimitation of frontiers or boundaries.

# Contents

●	<b>FIGURES</b>	<b>4</b>
●	<b>TABLES</b>	<b>4</b>
●	<b>BOXES</b>	<b>5</b>
●	<b>ABBREVIATIONS</b>	<b>5</b>
●	<b>EXECUTIVE SUMMARY</b>	<b>6</b>

<b>1.</b>	<b>INTRODUCTION</b>	<b>11</b>
●	1.1 Urbanisation and climate change	12
●	1.2 Understanding urban energy systems	15
●	1.3 Role of renewables in global energy transformation at the city level	18
●	1.4 About this report: Purpose, scope and structure	20

<b>2.</b>	<b>POTENTIAL OPPORTUNITIES FOR URBAN RENEWABLES</b>	<b>23</b>
●	2.1 Global mapping of city-level renewable energy targets	24
●	2.2 Spatial analysis of targets relative to local renewable energy resources and power plants	33

<b>3.</b>	<b>URBAN RENEWABLE ENERGY TECHNOLOGIES</b>	<b>51</b>
●	3.1 Solar energy	52
●	3.2 Bioenergy and waste-to-energy	60
●	3.3 Urban wind power	65
●	3.4 Direct use of geothermal energy	68
●	3.5 Smart grid development through innovation	70
●	3.6 District thermal energy networks	73

<b>4.</b>	<b>MODELLING TOOLS FOR URBAN ENERGY SYSTEM PLANNING</b>	<b>76</b>
●	4.1 Data challenges: Required data, temporal and spatial granularity, and accessibility	78
●	4.2 Modelling tools	83
●	4.3 Modelling challenges for developing countries	97
●	4.4 Looking forward in urban energy system planning	100

●	<b>REFERENCES</b>	<b>102</b>
---	-------------------	------------

# Figures

Figure 1:	World population growth, 1961–2016	13
Figure 2:	Global reduction of energy-related carbon emissions until 2050: Current plans vs. energy transformation	19
Figure 3:	Chapters in this report: Key steps to address urban challenges	22
Figure 4:	Geographic distribution of renewable energy targets and 100% renewable energy targets	25
Figure 5:	Global mapping of renewable energy target cities and climate zones	26
Figure 6:	City targets and urban population	30
Figure 7:	Cities in the top 30% for GHI vs. cities with renewable energy targets	35
Figure 8:	Distribution of solar PV power plants by GHI and geographic region	36
Figure 9:	Geographic distribution of solar power plants near cities	37
Figure 10:	Cities in the top 30% for wind power density vs. cities with renewable energy targets	40
Figure 11:	Distribution of wind power plants near cities by power density and region	41
Figure 12:	Power density and geographic distribution of wind power plants near cities	42
Figure 13:	Distribution of hydropower by region	44
Figure 14:	Bioenergy and waste-to-energy plants by region	45
Figure 15:	Global biomass power plants near cities and cities with high resource potential	47
Figure 16:	Global waste-to-energy plants near cities	47
Figure 17:	Distribution of geothermal power plants near cities by region	49
Figure 18:	Global median installed residential solar PV system size	53
Figure 19:	Rooftop-mounted solar PV-thermal hybrid system	59
Figure 20:	Savonius rotor and Darrieus rotor	67

# Tables

Table 1:	The number of cities with high solar potential in each dataset	34
Table 2:	The number of cities with high wind potential in each dataset	39
Table 3:	Median distance to nearest river segment and segment power for each dataset	43
Table 4:	The number of cities with high geothermal potential in each dataset	48
Table 5:	Key characteristics of open-loop and closed-loop geothermal heat pump systems	70

# Boxes

Box 1:	Renewable energy solutions for cities of the future	15
Box 2:	Innovation outlook: Smart charging for electric vehicles	17
Box 3:	District CHP and cooling systems in Umeå and Gothenburg, Sweden	61
Box 4:	Global Geothermal Alliance	68
Box 5:	Technical guidelines for the development of bankable renewable energy heating and cooling projects	74
Box 6:	Thermal energy storage in district heating and cooling	75

# Abbreviations

°C	degrees Celsius	LAC	Latin America and the Caribbean
BIPV	building-integrated photovoltaics	LEAP	Long-range Energy Alternatives Planning
CFD	computational fluid dynamics	m	metre
CHP	combined heat and power	m <sup>2</sup>	square metre
CO <sub>2</sub>	carbon dioxide	MESSAGE	Model for Energy Supply Strategy Alternatives and their General Environmental Impact
CSP	concentrated solar power	MtCO <sub>2</sub> e	million tonnes of CO <sub>2</sub> -equivalent
EUR	Euro	MW	megawatt
EV	electric vehicle	MW <sub>th</sub>	megawatt-thermal
GDP	gross domestic product	OSeMOSYS	Open Source Energy Modelling System
GHI	global horizontal irradiance	PV	photovoltaic
Gt	gigatonne	PV-T	solar photovoltaic-thermal
GW	gigawatt	R&D	research and development
GW <sub>th</sub>	gigawatt-thermal	TIMES	The Integrated MARKAL-EFOM System
HOMER	Hybrid Optimization of Multiple Energy Resources	TWh	terawatt-hour
ICT	information and communications technology	UNFCCC	United Nations Framework Convention on Climate Change
IPCC	Intergovernmental Panel on Climate Change	USD	United States dollar
IRENA	International Renewable Energy Agency	VRE	variable renewable energy
kW	kilowatt	W	watt
kWh	kilowatt-hour		

# EXECUTIVE SUMMARY



# Executive Summary

Cities are increasingly relevant to climate change mitigation and adaptation, not only because of their high contribution to global carbon emissions, but importantly because of their large potential to mitigate emissions of all kinds – as well as the rising need to build climate-resilient urban infrastructure for the future. Cities will need to accommodate two-thirds of the world's population in a liveable, low-carbon environment by 2050. Integrating renewable energy technologies into local energy systems has become part of the transformative action that is needed to realise such potential, backed by strong political will and technological advancement. Cities will also benefit greatly from the positive impacts that local development of renewables has on gross domestic product (GDP) and employment.

This report explores three key pillars of knowledge – on renewable energy resource potentials and renewable energy targets, technology options and urban energy system planning – that will enable cities to scale up their use of locally available renewables as they move to decarbonise their energy systems.

Setting renewable energy targets is an important component of cities' efforts to boost deployment of renewables. However, setting the right level of targets relies on good understanding of the availability of renewable energy resources, among other key factors. An analysis of targets set at the city level in relation to both locally available renewable energy resources and renewable power plants sited near cities reveals that:

- A growing number of cities have set renewable energy targets, but they are concentrated in Europe and North America, areas that have higher economic wealth and temperate-to-cold climates. Globally, more than 80% of the cities that have set a renewable energy target (671 cities in total) are in Europe and North America. Meanwhile, cities in Asia and Africa are falling behind in renewable energy target setting, even as their energy demand is expected to grow.
- Cities with renewable energy targets fall most commonly in the population range of 100 000 to 500 000 inhabitants. The majority of large and mega cities that have set renewable energy targets have pursued only a modest share of renewables in their energy mix.
- Hydropower, bioenergy and waste-to-energy already play a clear role in helping cities achieve their renewable energy targets and in decarbonising the energy mix. The use of solar and geothermal energy in cities is rising – although huge potential remains untapped – while the ability to harness wind power within cities is progressing but remains marginal.

Integrating local renewable energy technologies in cities faces various challenges, including legislative, policy, regulatory, financing, human capacity, aesthetic, design and urban planning barriers. To some extent, these barriers result from a lack of awareness of the renewable energy options and of the benefits of harnessing locally available renewable energy resources. Enhanced knowledge of applications of urban renewable energy technologies would help cities to plan and deploy renewables in urban areas.

This report also provides an overview of the most commonly used renewable energy technologies in cities, which include the following:

- **Solar photovoltaics (PV):** Urban-based solar PV systems are generally smaller in scale than ground-mounted systems located on the outskirts of cities. The median size of an installed residential PV system in 2018 was around 6.4 kilowatts. These systems are usually installed on, or integrated with, the roofs and façades of buildings. Scaling up PV applications in cities faces unique challenges including land constraints, the potential impact of rising shares of variable renewable energy on the local grid, and a lack of understanding of the economic implications of solar PV systems for local power suppliers and utilities.
- **Solar thermal:** Solar thermal systems, which rely on different types of solar collectors, are usually used for water and space heating and in some cases for industrial process heat. Increasingly, cities and countries have adopted building codes mandating the use of solar water heaters for all new buildings. In some cities, large solar collectors deliver the produced heat via district heating networks. Solar district heating was enabled by the transition of thermal networks towards low-temperature (below 60–70 degrees Celsius) district heating systems, known as the fourth generation. The solar system can be installed on the ground or on a building roof to supply heat for the building, community, district or city. However, in countries where natural gas is cheap and is the dominant heating source, solar thermal systems are less competitive in the absence of incentives or promotional schemes to support their social and environmental benefits.
- **Solar thermal cooling:** With the growth in global cooling demand – tripling from 600 terawatt-hours (TWh) in 1990 to 2 000 TWh in 2016, and projected to at least triple again by 2050 – solar thermal energy has gradually extended into the cooling sector. For cooling purposes, solar thermal is typically coupled with absorption chillers to lower peak demand on the grid during hot summers, reducing blackouts and the costs for grid enhancement.



- **Bioenergy and waste-to-energy:** These biomass-based energy sources can provide a relatively reliable and consistent supply of energy in comparison with solar PV. For cities, waste-to-energy offers a promising way to create a circular economy. However, the uncertainties of obtaining a sustainable supply of feedstock need to be addressed, and public acceptance remains a barrier to adopting waste-to-energy technologies.
- **Urban wind power:** Wind power has been used only marginally in cities and faces huge challenges to scaling up. While examples exist of urban wind turbines generating electricity, their performance needs to be improved substantially, and large-scale implementation is scarce. The use of wind turbines in urban environments is mainly in the research and development phase. The lack of experimental data is a big drawback in the development of urban wind turbines.
- **Geothermal energy for direct use:** With the need to decarbonise the heating sector, and recognising the potential and advantages of direct use of geothermal energy, applications in cities have been growing. Globally, the installed capacity of geothermal direct use has more than doubled since 2010, reaching 107 727 megawatts-thermal deployed across 88 countries in 2019. Geothermal technology is used mainly for space heating and cooling as well as for hot water in cities, through both stand-alone and district heating systems. For new cities or for the expansion of existing cities, installing geothermal energy systems would be much more cost-efficient than integrating the systems into established infrastructure.

For most cities, integrating the renewable energy technologies described above would require upgrading the urban infrastructure to accommodate them, without compromising on operational reliability and stability. This report highlights the importance of developing “smart” grids through innovation and the adoption of enabling technologies such as electric vehicles, energy storage systems and intelligent energy management systems to facilitate the integration of renewables into urban infrastructure. Smart grids present opportunities for using higher shares of variable renewables and for improvements in system efficiency. This is particularly important because future urban energy infrastructure will be highly integrated among different sectors, including power, heating and cooling, and transport.

Similarly, district heating networks that focus on integrating renewable energy sources offer new opportunities for renewables – such as solar thermal and low-temperature geothermal energy – to play a greater role in the energy supply. Through sector-coupled technologies such as heat pumps, electric boilers and thermal energy storage, thermal energy networks have been increasingly integrated with power systems.

Urban energy system planning that is focused specifically on integrating renewables into energy infrastructure is essential to advancing the world's energy transformation. Choosing the right modelling tool for this planning is critical. This report examines the commonly used modelling tools to support urban energy system planning, as well as the key challenges in undertaking such planning, particularly in developing countries.

These include data challenges related mainly to the accessibility and granularity of city-level energy data covering demand- and supply-side issues. The report evaluates seven modelling tools against a set of criteria to determine their effectiveness for use in renewable-centric urban energy system planning.

Notably, integrating renewable energy systems into the urban infrastructure of a new section or area of an existing city, or in new cities, would be less costly than integrating these systems in established areas because there would be less need to retrofit existing buildings and networks.

Existing or planned cities, therefore, need to shift the paradigm for their urban infrastructure development, with renewables playing a crucial role. This will help reduce the carbon footprints of cities in line with the global move towards a carbon-constrained future and, equally importantly, will enable cities to mitigate the negative impacts of global and local climate change.

To conclude, cities can rarely rely solely on local renewable energy sources to decarbonise their energy systems. However, before cities default to importing renewables from outside their boundaries, they should explore the opportunities to maximise the use of locally available renewable energy sources.

They should encourage distributed energy generation and an integrated approach to developing future urban infrastructure. This means coupling the power, buildings, transport, heating and industry sectors to achieve higher system efficiency and enhance climate resilience.





1.



# INTRODUCTION

# 1. Introduction



Cities are the economic engines of our planet, home to 55% of the world's population and representing 80% of the global gross domestic product (GDP) (UN DESA, 2018). Urbanisation has improved societal well-being by expanding economic activities and business opportunities, but it has also contributed to environmental damage and to global climate change, with fossil fuels powering most urban economic and social activities (UNDP, 2017; Keirstead and Shad, 2013).

According to the Intergovernmental Panel on Climate Change (IPCC), cities contribute 71–76% of global energy-related carbon dioxide (CO<sub>2</sub>) emissions. Fossil fuel and other emissions are associated with serious air pollution problems in more than 80% of cities worldwide, leading to an estimated 7 million premature deaths each year from diseases such as lung cancer, strokes and asthma (WHO, 2018).

With 2.5 billion people expected to be added to urban settlements over the next three decades (UN DESA, 2018), decisions made today about how to build sustainable energy systems for cities will shape our collective future. We need to find innovative ways to power the world's burgeoning urban areas while transforming existing systems. Benefiting from the dramatic declines in the cost of renewable power generation in recent years, renewables could play a key role in reshaping urban energy systems.

This also aligns with the objective of United Nations Sustainable Development Goal 7.2, which calls for greatly increasing the renewable share in the global energy mix by 2030.

This chapter provides the overarching context for the rise of renewables in cities and its potential to shape our future, and for the positioning of cities in the global energy transformation. In addition, it explores the untapped opportunities for locally available renewable energy, given the variety and maturity of technology applications in cities as well as the available modelling tools that can be used to identify feasible options and to craft sustainable energy strategies and climate action plans.

## 1.1 Urbanisation and climate change

The world's urban population has risen rapidly over the past half-century, with the number of city dwellers quadrupling since 1961 (Figure 1). Although the rate of urbanisation is expected to continue to slow – averaging 1.7% annually between 2018 and 2030 and 1.3% between 2030 and 2050 – the total urban population is projected to grow more than 50% by 2050 (from the 2015 level), according to the United Nations (UN). This means that by mid-century, two-thirds of the global population, or 6.7 billion people, will live in cities, with nearly all the additions (90%) expected to be in Asia and Africa (UN DESA, 2018).

Figure 1: World population growth, 1961–2016

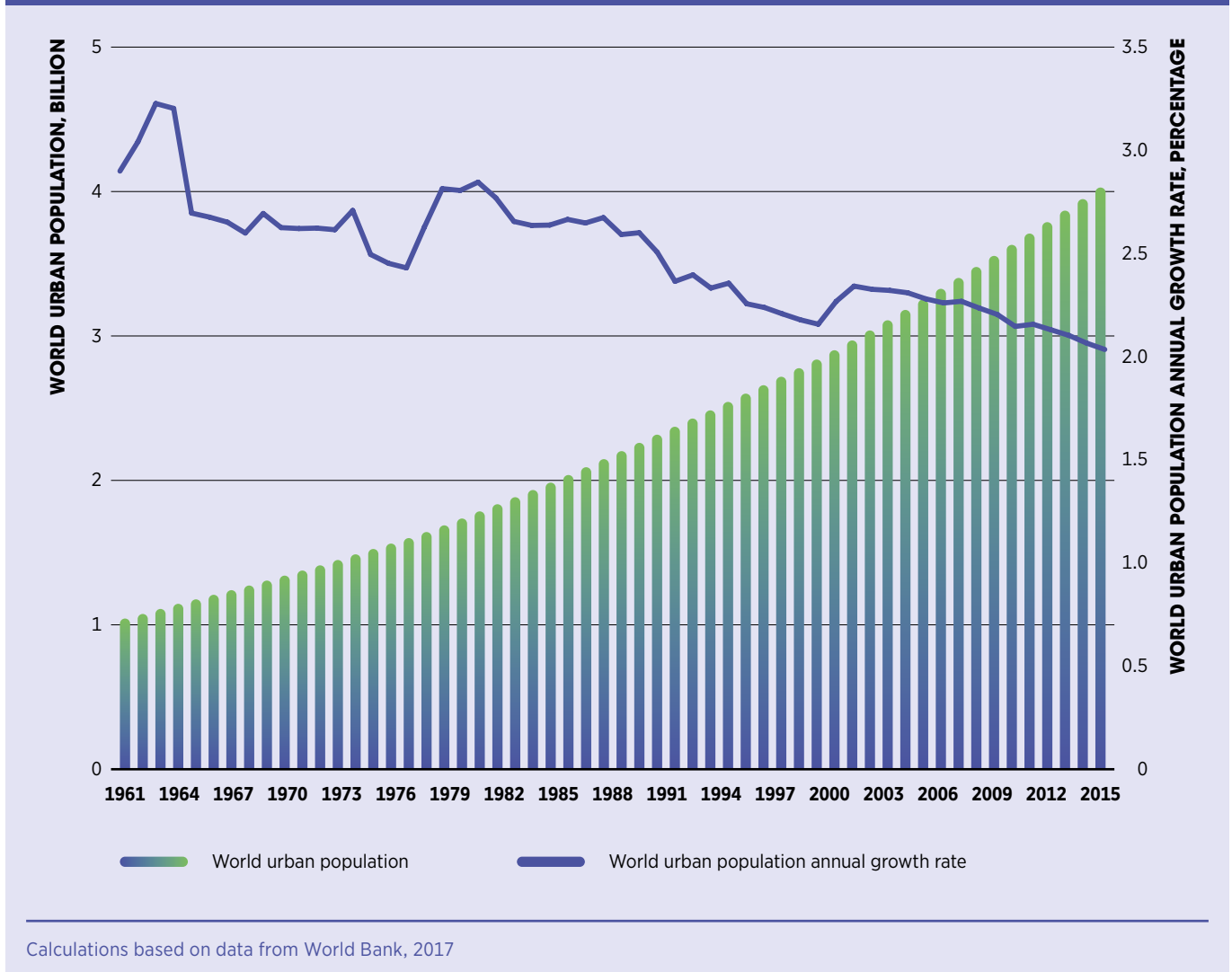

Currently, cities are responsible for 67–76% of global final energy consumption and for 71–76% of energy-related CO<sub>2</sub> emissions (Edenhofer *et al.*, 2014). Over the coming decades, the urbanisation process will necessarily coincide with the urgent need to decarbonise the global energy system, which is an essential undertaking if we intend to keep the average global temperature rise well below 2 degrees Celsius (°C), or 1.5 °C above pre-industrial levels – the climate objective set in the 2015 Paris Agreement.

Since the turn of the 21st century, the impacts of climate change have increasingly been felt in cities. More frequent and severe weather events, such as flooding, wind storms and heat waves, have crippled and even paralysed urban areas (UNISDR, 2016; Güneralp *et al.*, 2015). Globally, 17 of the 18 warmest years on record have occurred in the past two decades, according to the US National Aeronautics and Space Administration (NASA, 2019).

The heat wave of 2003 was among the most severe disasters of the past half-century, taking the lives of 30 000 people (UNEP, 2004). Summers are expected to be increasingly hotter and drier (Zscheischler and Seneviratne, 2017), resulting in greater use of air conditioning. This in turn increases ambient temperatures in the built environment and intensifies the urban heat island effect, making urban areas even warmer. These combined effects could cost cities up to 10.9% of GDP by the end of the 21st century (Estrada *et al.*, 2017).

The effects of climate change on the hydrological cycle influence regional climate patterns as well. Hotter and drier summers were a major factor behind the wildfires in the US state of California during 2017 and 2018, although human factors were also a key contributor to this disaster. The Australian bushfires of 2019–2020 that lasted for four months are another example of regional impacts. In November 2019, severe flooding in Venice, Italy submerged 85% of the urban area and cost the city EUR 1.1 billion (USD 1.23 billion<sup>1</sup>), with irreparable damage to some historic buildings (Henley and Giuffrida, 2019).

If sea levels keep rising, similar impacts would occur elsewhere in Europe, given that 70% of the region's large cities are located on or near the coast, and most are less than 10 metres above sea level (OECD, 2009). Globally, the IPCC warns about the increased impacts of sea-level rise on coastal populations and on small island states and territories (IPCC, 2019).

Cities are central in climate change mitigation, as they hold enormous potential to reduce emissions of all kinds. In addition, urban infrastructure must become more climate-resilient, particularly urban energy systems, given their pivotal role in maintaining the functionality of other infrastructure.

Renewable-based decentralised energy systems – with support from a mix of enabling technologies, such as energy storage (including battery and thermal storage), smart charging for electric vehicles (EVs), renewable power-to-heat and renewable power-to-hydrogen, digital technologies and intelligent energy management – have been deployed increasingly in and around cities in many countries. This trend is expected to continue, along with the emergence of innovative business models such as energy-as-a-service, aggregators, peer-to-peer electricity trading, community-ownership models, pay-as-you-go and urban energy planning, with the coupling of different sectors such as buildings, transport and industry (IRENA, 2019a).

At the same time, policy and regulatory frameworks and market design should be geared towards facilitating the shift to low-carbon and climate-resilient cities, as well as to local job creation, according to the forthcoming report *Renewable energy solutions for cities of the future* from the International Renewable Energy Agency (IRENA) (Box 1). In addition, innovative ways to operate power systems in cities will help make the energy transition based on renewables a reality, with distribution system operators playing a vital role. For example, advanced weather forecasting tools for solar and wind power generation can help integrate these renewable resources in today's power systems (IRENA, 2019a).

---

1 Exchange rate: USD 1.12/EUR 1.0 (December 2019)

**Box 1: Renewable energy solutions for cities of the future**

IRENA's forthcoming report *Renewable energy solutions for cities of the future* provides an analysis of cities' roles and policy tools to support the deployment of renewable energy in different sectors, with a focus on six medium-sized cities in China, Costa Rica and Uganda. These case studies examine best practices across vastly different socio-economic and administrative contexts.

Each case study outlines the national-level policies that frame renewable energy deployment at the local level, analyses the initiatives undertaken at the municipal level, and offers a summary of key lessons learned and considerations for taking solutions to scale. They also synthesise key takeaway messages for policy makers – at both the local and national levels – to help empower cities in their endeavour to contribute to a more sustainable energy future.

The policy analysis outlines key factors and sectoral approaches to deploy renewables in cities. To succeed, city planners and administrators need a range of skills and capacities to produce or procure renewable energy sources; to integrate them into urban energy systems such as in buildings and the transport sector; to enhance energy efficiency and pursue electrification; and to adopt appropriate urban planning tools and regulations.

---

Source: IRENA, forthcoming a

To realise such potential, transformative action is needed today. This action will create new opportunities and enable innovative solutions for addressing urban energy challenges. As cities strive to develop effective climate-friendly and resilient energy infrastructure strategies, as well as forward-looking action plans and investment decisions for the future, they will need to improve their knowledge of locally available renewable energy resources and of the various applications of urban renewable energy technologies, and to engage in proper planning for networked energy infrastructure using a low-carbon energy mix.

## 1.2 Understanding urban energy systems

Urban energy systems function similarly to any other energy supply system, with the distribution network and energy management systems providing a variety of services to meet the demand of energy consumers. However, urban energy systems are unique because of the intensive economic and social activity, innovations in technologies and business models, and direct environmental impacts in cities. Depending on the perspective taken, an urban energy system can be viewed as a thermodynamic, metabolic or complex system (Keirstead and Shad, 2013). Such systems can be analysed and understood in multiple ways.

One of the special characteristics of an urban energy system is that it serves as the socio-technical interface connecting the physical energy system with its end users – that is, urban dwellers. Therefore, consumer behaviour matters more than just the energy system alone.

This is particularly the case as disruptive technologies emerge that change the relationship between the producers and consumers of energy systems. Key technological innovations include rooftop solar PV systems with battery storage, net metering, smart energy management, highly efficient appliances, the Internet of Things, artificial intelligence fuelled by big data, and blockchain technology.

The growing decentralisation of generation through renewable energy sources and digital technologies is reshaping the dynamics between the physical energy system, typically operated by utilities, and energy consumers. In other words, the boundary between energy production and consumption is becoming blurry. Furthermore, innovative solutions that combine new business models built on such technologies, together with new regulations and innovative system operation practices for distribution grids, have offered cities a unique opportunity to revisit their relationship with the national energy system, both technically and institutionally.

By the same token, the electrification of end-use applications is critical for successful urban energy transformation. The increased use of sector coupling technologies such as heat pumps, EVs equipped with smart charging systems that support the operation of distribution power grids, as well as various energy storage technologies, has greatly facilitated the integration of variable renewable energy (VRE) sources – such as solar PV and wind – into the power system (see IRENA's *Innovation outlook: Smart charging for electric vehicles* (IRENA, 2019b), summarised in Box 2).

Innovations in energy systems have contributed to the expanding notion and practice of the prosumer, an actor that is both a consumer and a producer of energy, typically using a solar PV system to generate electricity. This is challenging the conventional dynamic between energy producers and consumers.

In the conventional model, the activities of urban dwellers generate demand for energy services, which the energy utilities provide through a complex and centralised energy infrastructure, and in return the consumers pay bills. In contrast, the electricity generated by prosumers (whether used for self-consumption or injected back to the grid) could potentially upend the traditional role of incumbents and would require the regulatory regime to reconcile this broader range of participants in future regulatory and market designs (Brown *et al.*, 2019; Hall and Roelich, 2016; Sioshansi, 2019).

In addition to prosumers, other new actors are emerging such as aggregators, which bundle several distributed energy resources into a single entity (a virtual power plant) to engage and trade in power or service markets (IRENA, 2019c).

In the field of heat provision, the shift to renewable energy sources has been much less than in the power sector, although the replacement of natural gas with solar thermal collectors and ground-source geothermal energy has occurred to some degree. For district heating networks, the heat flow is mainly unidirectional. Some experiments, such as ectogrid™, have tested the concept of low-temperature, micro-thermal grids to balance the waste heat and cooling energy sources among different users through decentralised heat pumps, thus requiring fewer energy inputs to compensate the losses. Such systems are being demonstrated in several cities, notably in Sweden, the Netherlands and the United Kingdom (UK).



Urban energy systems generally cannot operate independently of the national system, nor does it make economic sense for them to operate totally on their own. The relationships between urban and national energy systems can be examined in various ways. However, the dynamics of shaping such relationships have changed over the past decade. Cities have gradually become more aware of the impacts of energy production and consumption on a wide range of urban issues, from public health and the environment to transport, waste management and the job market.

Institutionally, cities need to exercise the authority they have in energy governance, particularly as they engage with the international community on the climate challenge, while also recognising the co-benefits of improving the local environment and boosting societal well-being. Over the past decade, a growing number of cities have sought to gain greater control over their energy systems, particularly by promoting renewable energy use. By 2019, some 671 cities had set at least one target favouring the use of renewables in their jurisdictions, and more than 60% of these cities had set a target to achieve 100% renewable energy, according to IRENA's analysis. Low-carbon development initiatives involving cities have increased both globally and regionally, thanks largely to efforts by international city-focused organisations such as the Covenant of Mayors for Climate & Energy, ICLEI-Local Governments for Sustainability and C40 Cities (see chapter 2).

In addition, a better understanding of technological options and energy planning authority at the local level is pivotal in the shift from centralised fossil fuels (large power stations located outside the city boundary) to decentralised renewable energy sources. Local energy sources incentivise cities to take responsibility for the energy system in their jurisdiction.

### Box 2: Innovation outlook: Smart charging for electric vehicles

IRENA's *Innovation outlook: Smart charging for electric vehicles* shows that steady reductions in the costs of renewable power generation are making electricity an attractive low-cost energy source to fuel the transport sector. Scaling up the deployment of electric vehicles also represents an opportunity for power system development, with the potential to add much-needed flexibility in electricity systems and to support the integration of high shares of renewables. However, achieving the best use of EVs requires a close look at which use cases would align best for both the transport and electricity sectors. Optimally, EVs powered by renewables can spawn widespread benefits for the grid without negatively impacting transport functionality. For that, smart charging and smart charging infrastructure are key, providing an intelligent interface that enables charging cycles that are adaptable to both the conditions of the power system and the needs of vehicle users.

Among other aspects, IRENA's innovation outlook discusses the potential impact of EV charging on the electric power distribution systems in cities and showcases how smart charging could reduce the costs associated with reinforcing local electricity grids. The report also highlights the ability of EV smart charging to facilitate the integration of VRE sources, including in and around cities. The discussion further explores the possible impact of other disruptive technologies that can potentially transform urban transport, such as autonomous vehicles and mobility-as-a-service.

Source: IRENA, 2019b

This can help cities develop sound urban energy strategies as well as investment plans and financing schemes. These can include the signing of power purchase agreements and the adoption of green bonds for energy infrastructure that is increasingly interconnected with other urban systems such as transport networks, waste management systems, and water supply and wastewater treatment facilities.

The strategy and planning processes for decentralised energy would inevitably interact with overall urban planning. Ultimately, energy consumption (and production, in the case of prosumers) in end-use sectors such as buildings, transport and industry are greatly influenced by how a city is planned and envisioned for both immediate-term development as well as long-term objectives.

### 1.3 Role of renewables in global energy transformation at the city level

The global energy landscape is undergoing a fundamental change, driven by rapid growth in the use of renewables thanks to dramatic declines in technology and system costs, particularly for solar PV and onshore wind power.

Key drivers include the digitalisation of the power sector, the increase in decentralised energy resources and the electrification of end-use sectors (most of which currently rely on fossil energy sources). Further fuelling this change is innovation in decentralised power generation technologies.

In addition to technology-driven systemic innovation in enabling technologies, combined with innovative business models, new market structures and regulations, and new ways of operating power distribution systems – all of which are reshaping the way that energy is produced, transported, distributed and consumed.

Since 2009, the average costs of solar PV have fallen 80%, while the costs of battery storage technologies are decreasing rapidly and could decline a further 60% over the coming decade. Overall, IRENA projects that cost reductions will continue in the coming years and that all currently commercially available renewable power generation technologies will be competitive with conventional fuels (IRENA, 2020a).

This is of great relevance to cities and provides a strong impetus for the deployment of renewables at the city level, as many of these disruptive technologies are enabling the scale-up of a renewable-based decentralised energy system. This helps cities mitigate their energy-related CO<sub>2</sub> emissions, which arise mostly from the buildings, transport and industry sectors. Moreover, cities will benefit tremendously from the positive impact that local renewable energy development has on GDP and employment.

According to IRENA's *Global Renewables Outlook*, global GDP will be 2.4% higher in 2050 under the Transforming Energy Scenario, characterised by accelerated uptake of renewables, than in the Planned Energy Scenario, and jobs in renewables will reach 42 million, up from some 11 million today (IRENA, 2020b). These figures underscore the key role that renewables have in global energy transformation at the city level.

To enable such scenarios to materialise, the potential must be recognised for renewables to achieve deep cuts in energy-related emissions in every sector. Renewable energy currently accounts for only 20% of urban energy use, with around two-thirds of this in the buildings sector and one-third in transport (IRENA, 2016).

However, as shown in Figure 2, renewables and electrification can potentially contribute to the 75% reduction in energy-related carbon emissions that is needed (compared to the Reference Case) by 2050 to keep global temperature rise well below 2 °C.

The potential to substitute fossil fuels in the end-use sectors of buildings, transport and industry, as well as in district heating, account for the lion’s share of the reductions (IRENA, 2019d).

Locally available renewable energy sources can also be used to decarbonise urban energy systems in various sectors by integrating them into small-scale, decentralised power systems, including mini-, micro and nano-grids<sup>2</sup>.

<sup>2</sup> Nanogrid is defined in Burmester *et al.* (2017).

Figure 2: **Global reduction of energy-related carbon emissions until 2050: Current plans vs. energy transformation**

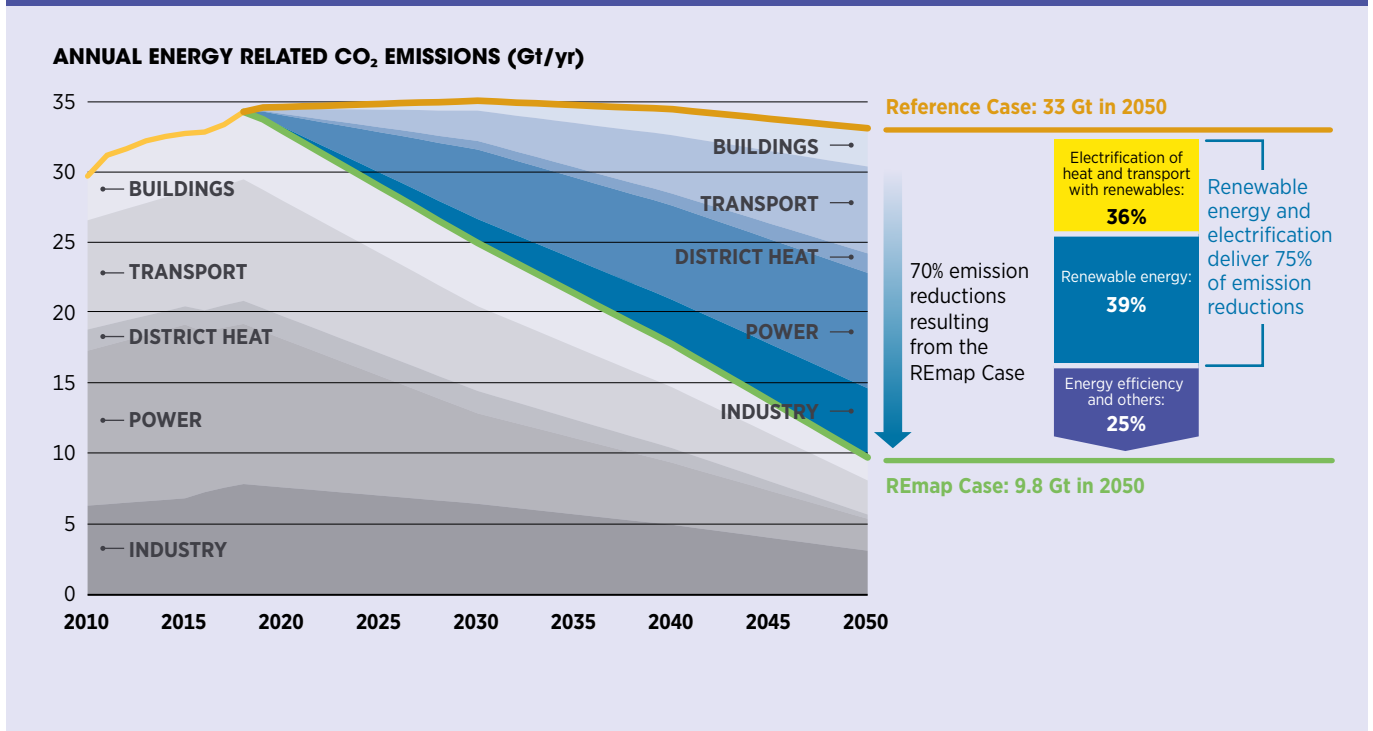

Reference Case = Pathway set by current policies and plans

REmap Case = IRENA’s roadmap for energy transformation with accelerated uptake of renewables

Source: IRENA, 2019d

## 1.4 About this report: Purpose, scope and structure

This report aims to provide fundamental knowledge about city-level renewable energy potentials, technology options for cities, and urban energy system planning to enable urban energy planners, municipal decision makers and their advisors to pursue strategic energy transformation at the city level. Renewable energy technology and project developers, financial institution professionals and investors, among other stakeholders, might also find some sections useful.

The report seeks to contribute to the discussion concerning the following two questions:

1. *What knowledge would be helpful to enable cities to maximise the use of their local renewable energy resources, if and when non-technical barriers are completely removed?* Through literature reviews and discussions with experts and some local energy professionals, three areas have been identified as most relevant in assessing the renewable energy options in cities: locally available renewable energy resources, renewable energy technologies applicable for the built environment, and planning tools for urban energy systems.

The scope of the analysis is on decentralised energy generation from locally available renewable energy resources, covering resource mapping in connection with renewable energy-related targets and initiatives, renewable energy technologies applicable in and around cities, and modelling tools for urban energy system planning – an important process to integrate local renewables into future urban energy infrastructure development.

The rationale is that cities would benefit from making their own assessments of local renewable energy resources and how those can best be utilised before considering energy “imports” from outside city boundaries. Thorough assessments in advance can help cities to make well-informed and forward-looking decisions.

This focus on locally available resources by no means reduces the importance of imports of renewable electricity (via transmission lines) from areas outside a city’s boundary. The interaction between local and national power grids is instrumental to enable both local and remote renewable energy resources to be used in the most efficient ways possible, provided that grid operations and transmission capacity allow for it.

2. *How would improving the technical knowledge at the local/sub-national levels help cities set realistic and obtainable targets and shape/develop well-informed and forward-looking local energy policies and strategies?* In the wake of the Paris Agreement, cities have been given a much greater role in addressing global climate change and are keen to identify opportunities to transform their energy systems towards a low- and zero-carbon energy future, while capitalising on the opportunities for social and economic development through local renewable energy development. More and more cities are trying to gain some control over their energy supply at the local level.

With improved technical knowledge, cities can set realistic and balanced policy objectives and take feasible measures to realise these objectives, particularly the trade-off options of using local renewables versus importing renewable energy from outside the city boundary.

The scope of this report is limited to technological and technical fronts of the urban energy regime; the analysis does not cover policies, legislation, regulations, and financial and economic incentive schemes, although their importance is recognised in the report.

While the report may be of greatest value to cities that are considering whether to harness their local renewable energy resources, it can also support frontrunners in this area in broadening their horizon and deepening their understanding of urban energy transformation.

Another purpose of this report is to bridge the communication gap between frontrunners and latecomers through further exchange of knowledge and thought-provoking discussions.

Overall, the report asserts that, in order to develop local renewable energy options and integrate them into an urban energy system plan, a city needs to: assess the availability of locally available renewable energy resources; understand the suitability of various renewable energy technologies for deployment in and/or around the city; preferably set a realistic and well-grounded target supporting local renewable energy development; and gain good knowledge on the modelling tools that can be used to develop urban energy system plans.

These are by no means the only key elements necessary for a city to transform its energy systems for a low- or zero-carbon future, given the diversity of cities across the globe.



Yet without these elements, a city would face challenges in maximising the use of local renewable energy resources, which is needed as the first step towards decarbonising the energy mix.

The structure of this report is as follows (see also Figure 3):

Chapter 1 serves as an introduction, presenting the context for the analysis and highlighting the role of cities in the global energy transformation.

Chapter 2 reveals the potential opportunities for exploiting local renewable energy resources in and around cities through analysis of: the targets that cities have set in support of renewables; the existing local renewable energy resources and power plants; and the current fossil fuel-based facilities located near cities that potentially could be replaced by alternative energy options. The assessment of local renewable energy resources in this chapter could help a city set a reasonable renewable energy-related target if it has not yet done so.

Chapter 3 discusses the key conversion technologies for urban renewable energy resources, covering solar PV, solar thermal, urban wind power, direct use of geothermal energy, bioenergy and waste-to-energy. Additionally, smart grids and demand response strategies as well as district energy networks are touched on.

Chapter 4 provides local energy professionals and planners with basic knowledge on the various modelling tools that can be used for urban energy system planning, as well as the opportunities and limitations. Specifically, it analyses and explores the different tools suitable for maximising the use of local renewables. A wide range of tools are available for a variety of applications, from determining the feasibility of renewable energy solutions in early planning stages to later system design (e.g., sizing and operation) and long-term municipal renewable energy strategy development.

The chapter focuses on understanding how these tools treat renewable energy options. Data challenges and key issues associated with planning in developing countries, among other relevant aspects, are also explored.

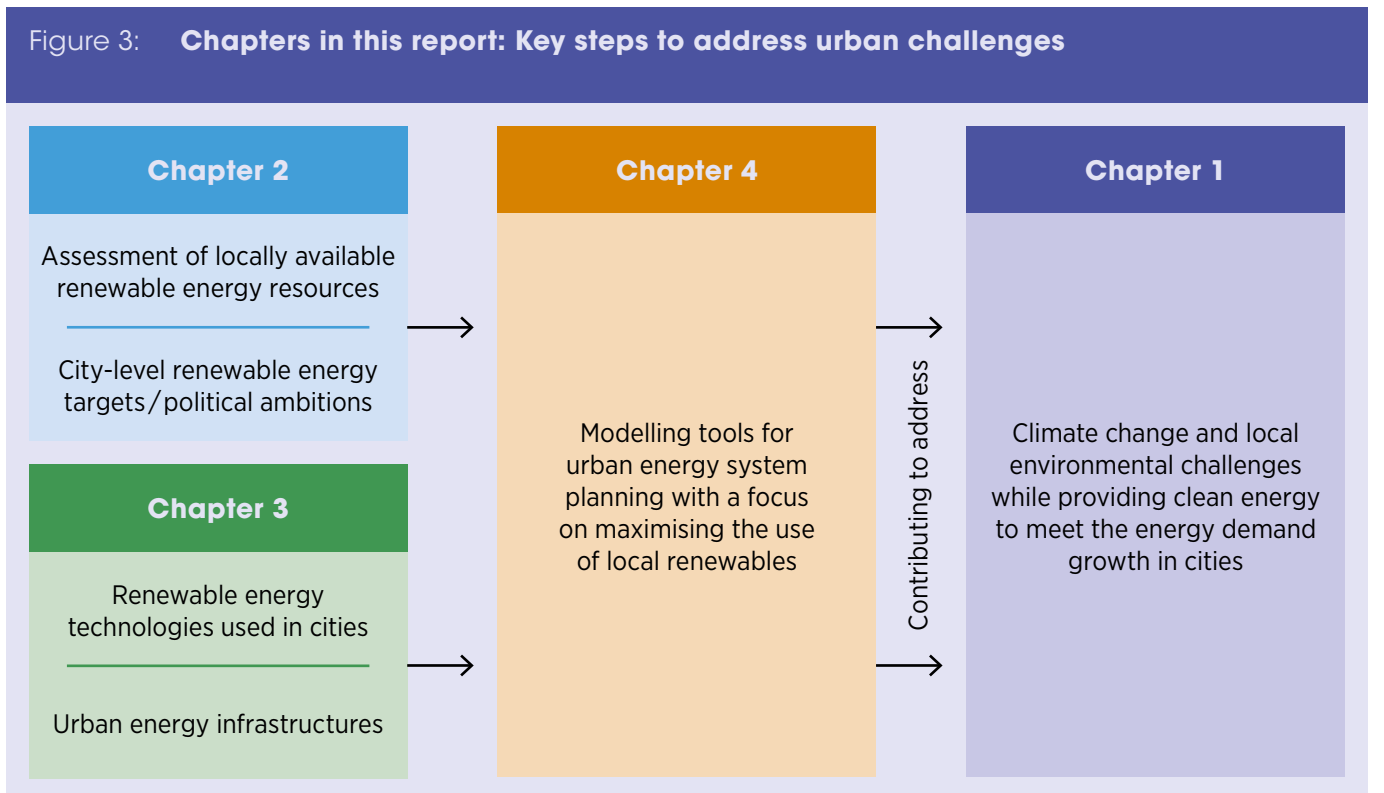



**2.**

**POTENTIAL OPPORTUNITIES  
FOR URBAN RENEWABLES**

## 2. Potential opportunities for urban renewables

This chapter highlights opportunities for accelerated uptake of renewables at the city level. Among the key points for cities to consider:

- A growing number of cities have set renewable energy targets, but more than 80% of these targets are in Europe and North America. This geographic unevenness of targets could be problematic in contributing to achieving, at the city level, the global climate target set under the Paris Agreement, given that Asia and Africa are projected to experience the most rapid growth in both their urban populations and energy demand.
- Cities with renewable energy targets fall most commonly in the population range of 100 000 to 500 000 inhabitants. The majority of large and mega cities that have set renewable energy targets have pursued only a modest share of renewables in their energy mix.
- The majority of the cities with renewable energy targets (551 out of 671 cities, or 82% of the total) are located in countries with high GDP per capita, revealing a clear correlation at present between cities that have renewable energy targets and their economic status.
- Hydropower, bioenergy and waste-to-energy already play a clear role in helping cities achieve their renewable energy targets and in decarbonising the energy mix. The use of solar and geothermal energy in cities is rising – although huge potential remains untapped – while the ability to harness wind power within cities is progressing but remains marginal. In some cities, peri-urban areas offer potential sites for renewable energy generation.

### 2.1 Global mapping of city-level renewable energy targets

Generally, setting an ambitious but attainable target indicates the level of political commitment that a government or organisation has made, and is an important component in the public policy-making process (Marsden and Bonsall, 2006; Hepburn, 2006). Over the past one-and-a-half decades, renewable energy targets at the national level have served as a critical enabler in accelerating the deployment of renewables by providing long-term political signals and policy direction to all the stakeholders involved, particularly manufacturers, investors and project developers (IRENA, 2015a).

Renewable energy targets at the city level can in principle function similarly, even though cities often have limited governance authority over energy given their interconnections with the national energy systems in most countries.

Over the past decade, the number of cities that have set targets to support renewable energy has increased more than six-fold, from less than 100 cities in 2010 to 671 cities spanning 70 countries in 2019. Altogether, cities have set nearly 1 000 renewable-related targets of all types<sup>3</sup>, with some cities having more than one target. Most of these cities are in Europe and North America, while Asia and Africa lag in target setting.

In general, small to medium-size cities have been most engaged, although a few megacities have been frontrunners in urban energy transformation.

<sup>3</sup> This includes city-level, municipal-level and community-level, as well as sectoral and technology-specific, renewable energy targets, which are set in either absolute or relative terms; it excludes targets set for carbon emission reduction, energy efficiency improvements and electrification targets (although these can indirectly impact renewable energy development).



Global and regional initiatives involving cities in low-carbon development have interplayed positively with local renewable energy target setting through effective information exchange, resource sharing and peer pressure related to the target setting and use of renewables.

Yet a dedicated target is not the only instrument to increase renewable energy use. Nor are renewable energy targets the only indicator for tracking progress.

Even without targets, renewable energy applications have scaled up greatly in the past decade, thanks to rapid cost reductions in solar PV panels and battery storage systems, helping to meet growing demand for urban and especially rural electrification.

**A growing number of cities have set renewable energy targets, but they are concentrated in Europe and North America, areas that have higher economic wealth and temperate-to-cold climates.**

Cities setting targets for renewables are mainly located in wealthier regions with cooler climates.

Of the 671 cities with targets analysed in this report<sup>4</sup>, 45% are in Europe and 36% are in North America. A similar geographic profile exists for the sub-set of 428 cities that have 100% renewable energy targets, as illustrated in Figure 4.

<sup>4</sup> A database of city renewable energy targets was compiled using data from the CDP (city renewable energy targets from 2015 to 2018) (CDP, 2019a), REN21 (REN21, 2019a), the carbonn Climate Registry (carbonn Center, 2019), the Global 100% RE Platform (100% Renewables, 2019), US Climate Mayors (Climate Mayors, 2018), the US Conference of Mayors (US Conference of Mayors, 2020), the Sierra Club (Sierra Club, 2019), UK100 (UK100, 2019) and the 100% Renewable Energy Atlas (100% Renewable Energy Atlas, 2019a). This database is not comprehensive and does not include all city renewable energy targets.

Figure 4: **Geographic distribution of renewable energy targets and 100% renewable energy targets**

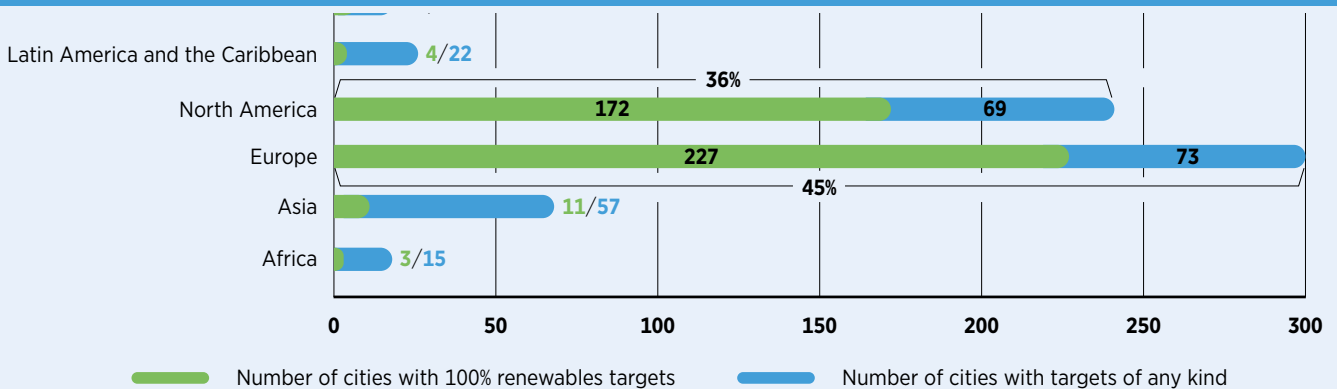

Based on IRENA analysis

The fact that more than 80% of the cities that have renewable energy targets are in Europe and North America, regions that typically have temperate or cold climate zones (Figure 5), has a marked impact on energy demand and on the types of energy services needed – particularly heating in winter. Of the 980 renewable-related targets (of all types) assessed, only around 50 are dedicated heating targets<sup>5</sup>, or less than 5% of the total.

By comparison, 389 targets (40% of the total) are aimed at renewable electricity generation. However, the remaining 55% of targets for all renewables cover heating as well, reflecting the trend of electrification in end-use sectors (including heating), which is taking advantage of the rapid scale-up in solar PV and wind generation thanks to dramatic cost declines in these technologies in the past decade.

<sup>5</sup> This includes 49 dedicated heating-only targets and 6 targets covering electricity combined with either heating or transport.

Figure 5: Global mapping of renewable energy target cities and climate zones

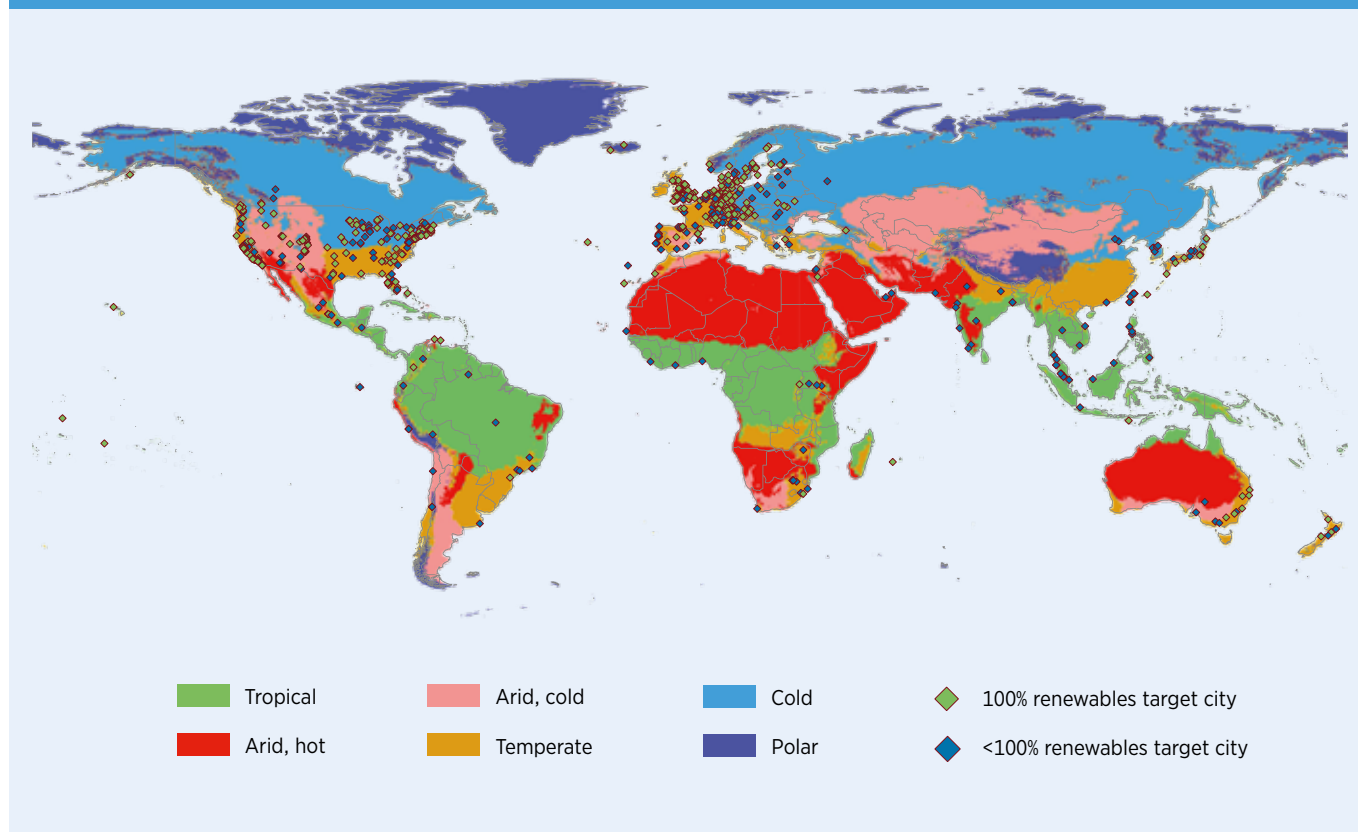

Based on IRENA analysis and Beck *et al.*, 2018

*Disclaimer:* Boundaries and names shown on this map do not imply any official endorsement or acceptance by IRENA.

The analysis of targets also reveals a correlation between cities that have renewable energy targets and a city's overall economic status. Most of the cities that have renewable energy targets (551 out of 671 cities, or 82% of the total) are found in the 30 countries with the highest GDP per capita, based on categorisation by the International Monetary Fund (IMF, 2019).

Meanwhile, the ten countries with the highest GDP per capita (Luxembourg, Switzerland, Norway, Ireland, Qatar, Iceland, the United States (US), Singapore, Denmark and Australia) are home to around 40% of the cities with renewable energy targets. This is in sharp contrast to the 30 countries with the lowest GDP per capita, which have only four cities with targets.

Looking ahead, the use of renewable energy sources needs to be scaled up massively in rapidly expanding or new cities in developing countries. Asia and Africa are important in this regard, given that they are projected to experience the most rapid growth, both in their urban populations and their energy demand. Renewables can enable developing countries to avoid “lock-in” to the fossil energy trap. Renewable energy targets set at the city level, among other policy tools, can be helpful in providing a political signal and some indication of policy consistency to potential investors and project developers for urban renewable energy development.

Regions with rising energy demand hold great resource potential, yet mostly lack targets for renewables

### Asia and Africa are falling behind in renewable energy target setting.

According to the UN, an additional 2.5 billion people are expected to become urban dwellers in the next three decades, 90% of them in Asia and Africa; altogether, two-thirds of the world population is projected to live in urban areas by 2050 (UN DESA, 2015; UN DESA, 2016).

**Africa** has been steadily urbanising over the past three decades. In 2015, 43% of the region's population lived in cities, a 12% increase from the 1990 level (UNECA, 2017). The urbanisation trend is expected to accelerate at a rate of between 2.7% and 3.6% from now until 2050, according to the UN (UN DESA, 2018). This would add around 1 billion urban dwellers in Africa by 2050, representing 40% of the global increase in the same period.

As in more advanced developing countries, urbanisation in Africa has been driven largely by overall economic growth, improved productivity in the agricultural sector, industrialisation and the growing investment in urban infrastructure (Cilliers *et al.*, 2011). All these drivers have implications for energy production and consumption. As is widely recognised, economic progress cannot be sustained without a reliable energy supply and its underlying infrastructure.

Africa remains home to nearly 600 million people without electricity access. Urbanisation in the continent's less-developed regions is driven heavily by population growth and by the desire to seek opportunities for a better life in cities. Yet even in urban areas of Africa, 60% of the inhabitants live in slum areas with limited access to electricity, clean cooking fuels and job opportunities (Brookings, 2020).

Renewable energy resources are abundant across the region, with estimated resource potentials exceeding 10 terawatts of solar, 110 gigawatts (GW) of wind, 100 GW of hydropower, 15 GW of geothermal and a large amount of biomass including organic municipal wastes (Hott, 2018; IRENA, 2015b).

Hydropower remains important across much of Africa, and in most countries wind and solar energy show excellent potential. Many African countries have solar irradiation endowments above 2 200 kilowatt-hours per square metre (kWh/m<sup>2</sup>) per year, double that of Germany. By comparison, geothermal resources for electricity generation are largely limited to eastern Africa, and the highest potential for biofuel production lies in sub-Saharan Africa (IRENA, 2015c).

In this context, how African countries reconcile their exploitation of renewable energy resources with the development of sustainable cities has profound implications for the region's sustainable economic and social development.

Although only 18 African cities have renewable energy targets, as many as 225 African cities (202 in sub-Saharan Africa and 23 in North Africa) had committed to greenhouse gas reductions through the Global Covenant of Mayors for Climate & Energy as of 2018 (Covenant of Mayors for Climate & Energy, 2020). Renewable energy offers promising options for African countries to meet their growing energy demand while also reducing their carbon footprints and gaining co-benefits such as better air quality (including indoor), improved public health and greater resilience to extreme weather events such as storms, flooding and wildfires.

Compared to developed countries, African countries are better positioned to afford such technological leapfrogging because they are not locked in to existing energy infrastructure, and the costs would be much lower. The link between greenhouse gas reduction and the use of renewables needs to be better established and understood, particularly among local decision makers and their advisors.

In the long run, any prosperity achieved in Africa may not be maintained without a sustainable energy system. If cities aim to develop sustainable and climate-resilient energy systems, renewables must be given a central role.

In **Asia**, the urban population has increased rapidly in the last 30 years, rising from 1.04 billion in 1990 to 2.27 billion in 2018. It is expected to reach 2.80 billion in 2030 and 3.48 billion in 2050. While Asia's projected urbanisation rate for 2050 (66.2%) is lower than the projected global average (68.4%), the continent will still account for more than half of the global urban population that year (UN DESA, 2019). Asia is also home to the world's largest cities, including 20 of the 33 global megacities, a number that is expected to increase to 27 (out of 43 megacities) by 2030 (UN DESA, 2018).

The expansion of Asia's urban population is driven by both globalisation and regional economic growth. Urbanisation has helped lift many people out of poverty, although the absolute number of slum dwellers has increased, highlighting the problems that arise when cities are not equipped to deal with rapid population growth (UN-Habitat, 2010).

Asian cities continue to face many challenges to sustainable development, including their ability to provide economic opportunity, develop housing and infrastructure, and manage air pollution and high carbon emissions (UN ESCAP and UN-Habitat, 2015; REN21, 2019b). The rise in the urban population also increases energy demand. Many cities face energy shortages (Dulal *et al.*, 2013), and energy security issues will become more prevalent as Asian countries turn from exporters to importers of non-renewable energy (Chang and Li, 2014).

To decrease reliance on imported energy, these countries would benefit from increasing local renewable energy generation, which would also help reduce air pollution and carbon emissions while improving energy access in poorer areas (Vliet *et al.*, 2012).

Asia has a rich yet mostly unexploited renewable energy potential that varies by region, with solar and biomass concentrated more in the tropical south, wind concentrated more in the north, and geothermal energy abundant for both electricity generation and direct use. Hydropower is more evenly distributed across Asia and is the renewable energy resource that has been exploited the most, with a total installed capacity of 593 GW, or 47% of the global hydropower capacity (IRENA, 2019e). However, hydropower tends to be more prevalent in mountainous countries such as Nepal and Bhutan, whereas countries that are rapidly growing and urbanising generally depend more heavily on fossil fuels (Dulal *et al.*, 2013).

The policy landscape of renewable energy is slowly expanding, which is critical in enabling cities to avoid lock-in to high-emission development pathways. Currently Asia is home to 70 cities that have renewable energy targets (10% of the global total), but the level of ambition of these targets tends to be low, with only 11 cities (3%) aiming for 100% renewable energy. The Cities Development Initiative for Asia aids cities in achieving their targets by bridging the gap between city development plans and the sustainable implementation of infrastructure projects (CDIA, 2020).

Overall, both existing and future cities in Asia and Africa must shift their paradigm of urban infrastructure development, with renewables playing a crucial role with or without specific targets. This will help reduce the carbon footprints of cities in line with the global move towards a carbon-constrained future, and more importantly will enable cities to mitigate the negative impacts of global and local climate change.

### **Urban population and renewable energy targets**

To some extent renewable energy target setting correlates with the size of the urban population. Most commonly, cities with renewable energy targets fall in the medium population range of 100 000 to 500 000 inhabitants (Figure 6). Analysis also reveals that the larger the city size, the lower the share of 100% renewable targets compared to the total number of targets. This is in part because larger cities have extensive existing infrastructure, making them more difficult to decarbonise. In addition, most of the world's largest cities are in developing countries that have a lower penetration of renewables; in 2018, only 4 of the 33 global megacities were in Europe or North America (UN DESA, 2018).

Figure 6: City targets and urban population

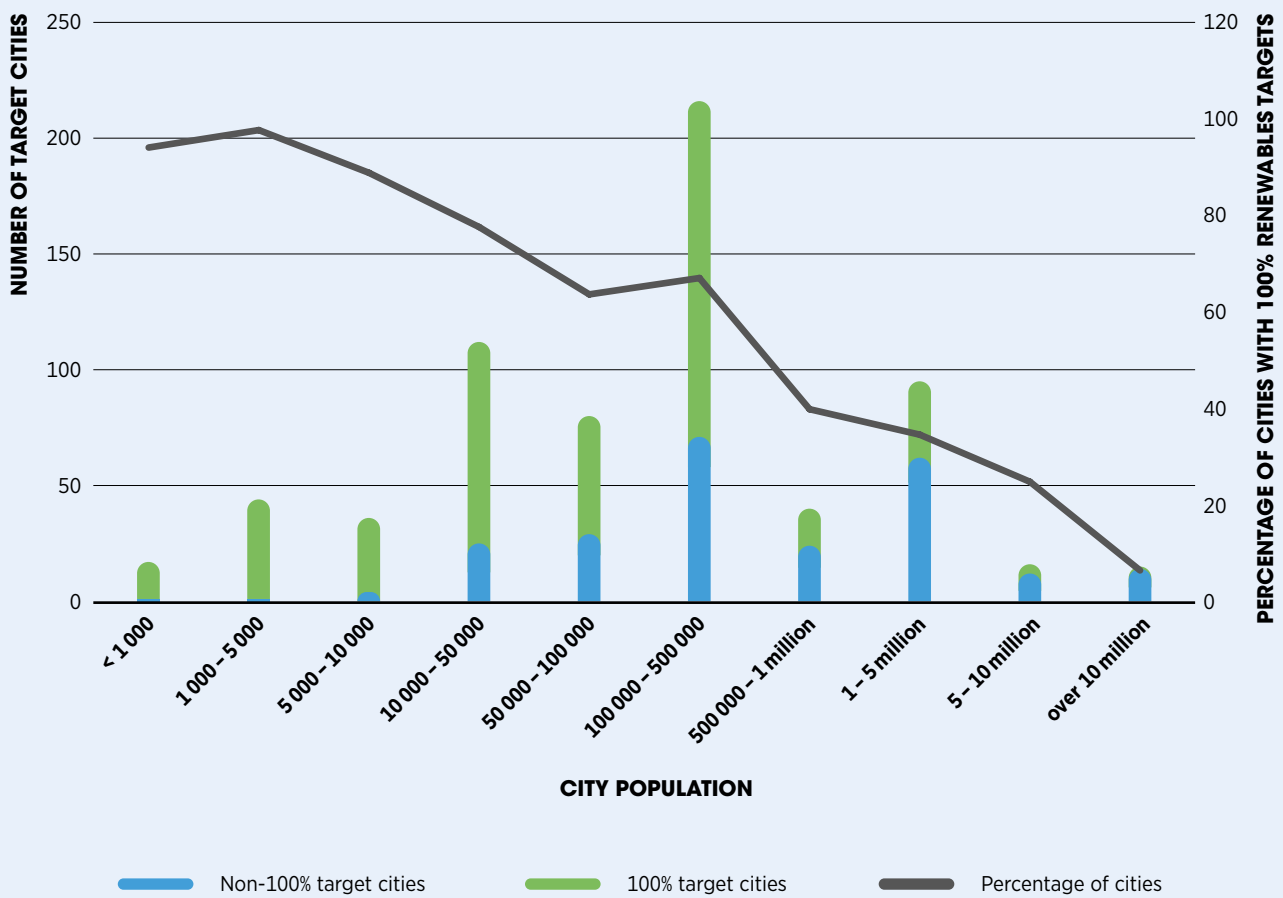

Based on IRENA analysis

Most of the large and mega cities that have already to date adopted renewable energy targets have deployed renewables at only a modest level. Just one megacity (Los Angeles, with 10 million inhabitants) has a 100% renewable target, which is set for 2045 (Sierra Club, 2019).

Other megacities show much lower levels of ambition, with all but two (São Paulo and Shenzhen) targeting renewable shares below 30%. Only 4 cities in the population range of 5 million to 10 million (Atlanta, Barcelona, Madrid and Toronto) and 33 cities in the range of 1 million to 5 million had targets for 100% renewables.

Large regional variation exists in the population sizes of cities with renewable energy targets. Generally, the trend towards target setting in new regions is started by larger cities that have more rapid information flow and more active peer communication, and then diffuses to smaller cities that have the capability to set even more ambitious targets. In developed regions like Europe and North America, a wide range of cities have targets.

This contrasts with both Africa and Latin America and the Caribbean, which are at earlier stages of development. All African cities with targets have populations greater than 100 000, while all cities with targets in Latin America and the Caribbean have populations above 50 000, with the exception of Las Gaviotas, Colombia, an ecovillage of 200 people (100% Renewable Energy Atlas, 2019b). In Oceania and Asia, most of the cities with targets are larger cities, although some smaller cities have also adopted renewable energy targets.

Economic opportunity has been identified as a key driver for target setting (Martinez *et al.*, 2018; ICLEI, 2016; REN21, 2019a; REN21, ISEP and ICLEI, 2012). In general, cities in Europe and North America that are in the population range of 100 000 to 500 000 have well-established and diverse economies, with the potential for continued growth. Promoting renewables in these cities could produce clean energy to meet urban energy demand while also fostering new businesses and creating local job opportunities.

Even greater opportunities exist in cities that are still expanding. Here, integrating renewable energy systems into the urban infrastructure would be less costly because there would be less need to retrofit existing buildings and networks. Setting a target for renewables in such cities would encourage local governments to develop a long-term and holistic urban energy infrastructure plan. Similarly, increasing renewable shares in planned or new cities would be beneficial for their future emissions reductions. Between 2018 and 2030, some 18 additional cities with populations in the range of 500 000 to 1 million are projected to emerge every year, or a total of 710 cities by 2030 (up from 598 in 2018) (UN DESA, 2018). How to power these new cities or districts with low-carbon and sustainable energy sources will be a key factor determining global success in the battle against climate change.

### **Initiatives underpinning renewable energy target-setting**

Many global and regional initiatives exist that engage cities in low-carbon development and that encourage them to adopt targets and to connect with one other for effective information exchange. Some of these efforts have shared goals and tracking strategies, whereas others leave cities to choose their own goals. Regardless, they facilitate local renewable energy target setting through effective information exchange, resource sharing and peer pressure or inspiration. Analysis indicates that cities that have a renewable energy target are three times more likely than their peers to take action (C40 Cities, 2019).

Some of the largest and most ambitious initiatives supporting target setting are summarised below:

- Covenant of Mayors for Climate & Energy:** Although this is the most widespread initiative, it targets emission reductions rather than support for renewable energy specifically. As of December 2019, 10 086 cities had signed on to the Covenant, agreeing to reduce their CO<sub>2</sub> emissions by at least 20% by 2020 or 40% by 2030 (compared to 1990 levels). In addition, 6 413 cities had submitted action plans to achieve their goals. The initiative started in the European Union (EU) but has grown to include the Middle East and parts of Africa (Covenant of Mayors for Climate & Energy, 2019). An analysis of the 9 120 signatories as of 2018 found that their combined emission reduction potential was 1 440 million tonnes of CO<sub>2</sub>-equivalent (MtCO<sub>2</sub>e) by 2030 (Data Driven Yale *et al.*, 2018).
  - C40 Cities:** As of December 2019, 94 cities, representing 25% of global GDP and one-twelfth of the world's population, had agreed to the goal of achieving net carbon neutrality by 2050 under the C40 initiative. C40 cities must develop climate action plans before 2020 consistent with the objectives of the Paris Agreement. The 94 networked cities have more than 10 000 planned actions (C40 Cities, 2019) – many of which involve the deployment of renewable energy – and the total emission reduction potential is 820 MtCO<sub>2</sub>e by 2030 (Data Driven Yale *et al.*, 2018).
  - Carbon Neutral Cities Alliance:** This global network of megacities is working to cut greenhouse gas emissions 80% to 100% by 2050 or sooner. The Alliance has invested USD 2.4 million in 27 innovation projects across these cities (Carbon Neutral Cities Alliance, 2019).
  - ICLEI – Local Governments for Sustainability's carbonn Climate Registry:** The carbonn Registry presents a unified platform for sub-national climate action reporting. It includes 1 066 entities (mostly cities and some regions) with 1 870 climate targets and 6 874 mitigation and adaptation actions, which would lead to a 26.8 gigatonne (Gt) reduction in CO<sub>2</sub>-equivalent emissions by 2050 (carbonn Center, 2019).
  - Sierra Club:** As of December 2019, the Sierra Club's Ready For RE100 initiative in the United States included 145 cities, 12 counties and 9 states that have committed to 100% renewable power in at least one sector. Six of these cities have already achieved their 100% targets (Sierra Club, 2019). The initiative is growing rapidly. As of 2017, when it included only 50 cities, 4 counties and the state of Hawaii, it already represented a potential reduction of 23 million tonnes of CO<sub>2</sub> and an increase in renewable energy of 2 000 megawatts (MW) of wind energy equivalent by 2030 (Sierra Club, 2017).
  - UK100:** Through this network, 90 local government leaders in the UK have pledged to shift to 100% renewable energy by 2050. They are running campaigns to increase investment in decarbonisation technology, communicate climate change and eliminate air pollution. Although UK100 represents the most ambitious unified renewable energy target of the above initiatives, it is non-binding (UK100, 2019).
- Other notable initiatives include the US Climate Mayors (400 members), the US Conference of Mayors Climate Protection Agreement (1 066 signatories) and the Inter-American Development Bank's Cities Network in Latin America and the Caribbean (over 160 cities) (Climate Mayors, 2018; US Conference of Mayors, 2020; IDB, 2020).



## 2.2 Spatial analysis of targets relative to local renewable energy resources and power plants

This section explores the potential spatial relationships between cities that have renewable energy targets (including targets for 100% renewables), the renewable energy potential<sup>6</sup> and existing local renewable energy power plants. For comparison, fossil-based power plants located close to cities are also considered against the renewable energy resource potential and the existing renewable energy targets to present the potential opportunities of substitution.

The city database used was the UN Statistics Division (UN Statistics, 2020), which collects data for global cities through annually dispatched questionnaires.

This database has a total of 4 591 cities varying in population size from 100 000 inhabitants to megacities with more than 10 million inhabitants, which matches the range of populations identified for cities with renewable energy targets.

The database of power plants (including both renewable- and fossil-based) was built using information on the capacity and location of global power plants from the World Resources Institute (Byers *et al.*, 2019), from GlobalData (GlobalData, 2019) and from the UDI World Electric Power Plants Database (WEPP) (S&P Global Platts, 2018). A spatial clustering algorithm was applied to geocode the power plants using two different thresholds of proximity to the nearest city centre: 20 kilometres for hydropower and solar PV farms, and 50 kilometres for all other power plants. Additionally, a database cleanse was performed to ensure the optimal merge based on the characteristics for each technology at a given city.

---

<sup>6</sup> The resource data used are collected from multiple sources with different levels of granularity, and are used for indicative analysis only.

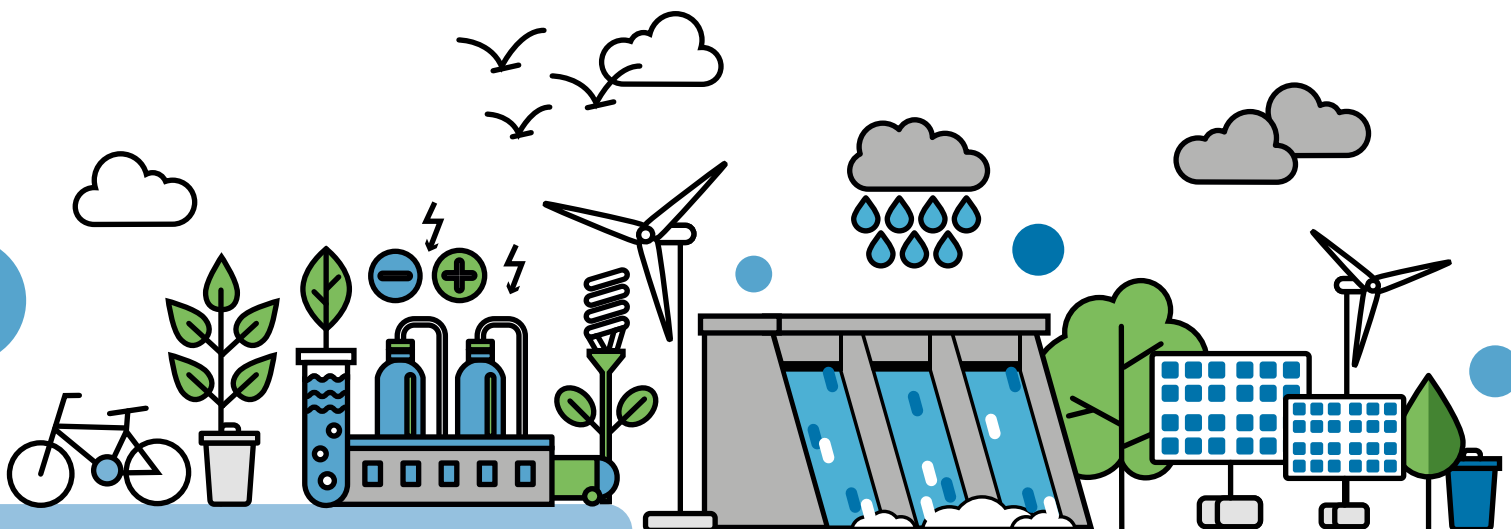

## SOLAR ENERGY

**While solar use in cities is rising, enormous potential remains untapped.**

### *Solar irradiance*

Based on the analysis, 95% of the cities that have the highest solar potential (*i.e.*, cities in the top 10% for global horizontal irradiance, or GHI) do not have a set target for supporting renewable energy development (Table 1). The exceptions are Leon de los Almadras (Mexico), Puebla de Zaragoza (Mexico) and Kisumu (Kenya), none of which has an ambitious target for 100% renewables. Even among the cities in the top 30% for solar potential, only 6% (39 cities) have a renewable energy target and only 2% (14 cities) have a target for 100% renewables. In absolute terms, this suggests that 582 cities that have excellent solar energy resource potential lack the political commitment or ambition to scale up their use of renewables (especially solar) to meet energy demand.

Most of the cities with high GHI are in the Middle East and Africa, in Latin America and the Caribbean, and in parts of Asia, whereas most of the cities that have renewable energy targets are in Europe and North America and have only average GHI (Figure 7).



A further detailed survey and analysis could reveal business opportunities in those cities even without any policy support.

That said, having low solar potential does not necessarily pose a barrier to the use of solar energy in cities, nor does it preclude achieving renewable energy targets in an economically viable manner. For example, Glasgow, Scotland in the UK has a GHI of 2.41. Although solar is not the city’s primary source of renewable energy, Glasgow still makes use of both solar PV and solar thermal. The local government plans to grow the solar PV capacity from around 3 MW in 2014 to 9.6 GW by 2030 (Glasgow City Council, 2014).

**Table 1: The number of cities with high solar potential in each dataset**

Percentile	GHI (kWh/m <sup>2</sup> ) average daily sum	Studied city (dataset)	Number of cities with renewable energy target	Number of cities with 100% target
Top 10	6.126	66	3	0
Top 20	5.851	248	17	6
Top 30	5.493	621	39	14

Based on IRENA analysis

Figure 7: Cities in the top 30% for GHI vs. cities with renewable energy targets

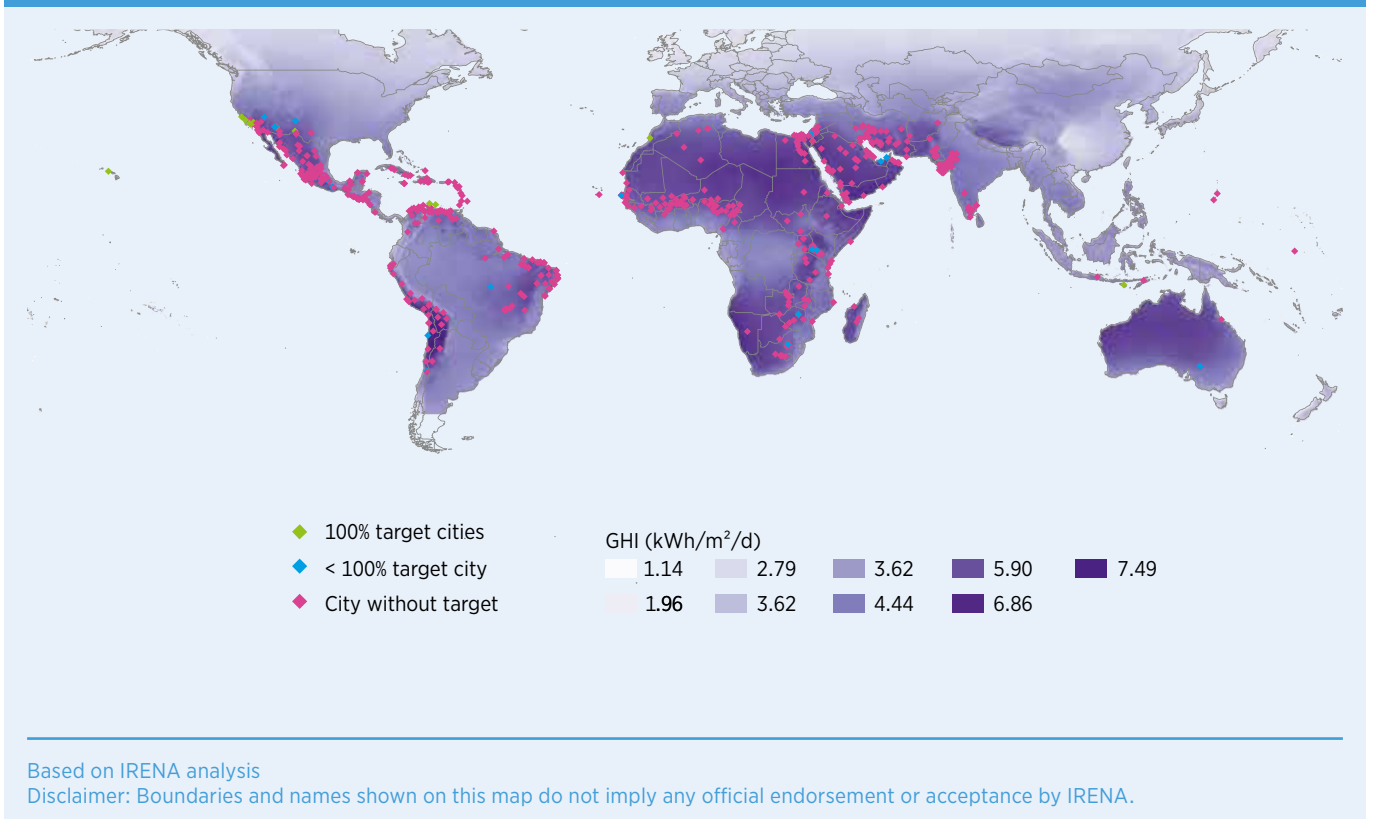
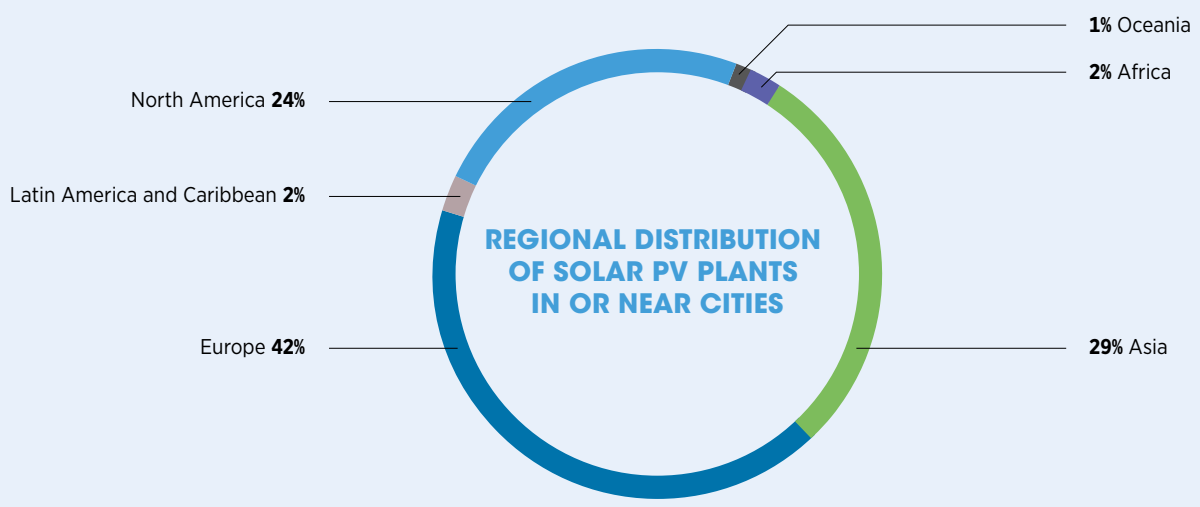
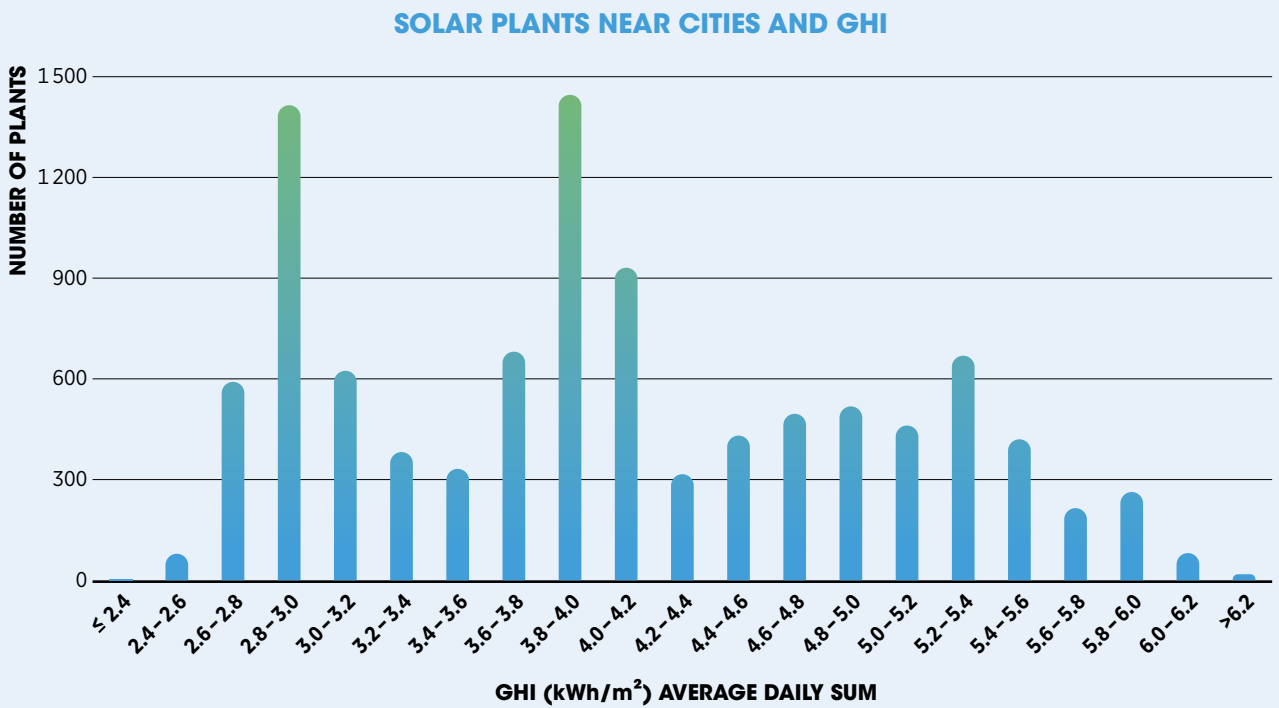

Figure 8: Distribution of solar PV power plants by GHI and geographic region



Based on IRENA analysis

*Solar power plants*

There is less correlation between a city’s solar resource potential and the existing distribution of solar power plants. Of the total 10 138 solar PV power plants located near cities, around 57% are in areas with GHI in the lower range of 2.8 to 4.2 kWh/m<sup>2</sup> (Figure 8). Nearly half of the solar power plants are in Europe, despite the region’s relatively low average GHI, and Asia and North America each account for around one-quarter of plants; combined, these three regions represent 95% of the global total of solar power plants.

Across Asia, the frontrunners in solar power plant deployment near cities are China, Japan, India and several south-eastern countries such as the Philippines and Thailand (Figure 9). In the US and China, most plants are distributed across coastal regions, the powerhouses for the world’s two biggest economies.

The average size of solar plants near cities in Europe, North America and Asia is between 4.64 MW and 13.75 MW, which is fairly small compared to the utility-scale solar plants located in remote areas, which have capacities of several hundred megawatts and above.

Figure 9: **Geographic distribution of solar power plants near cities**

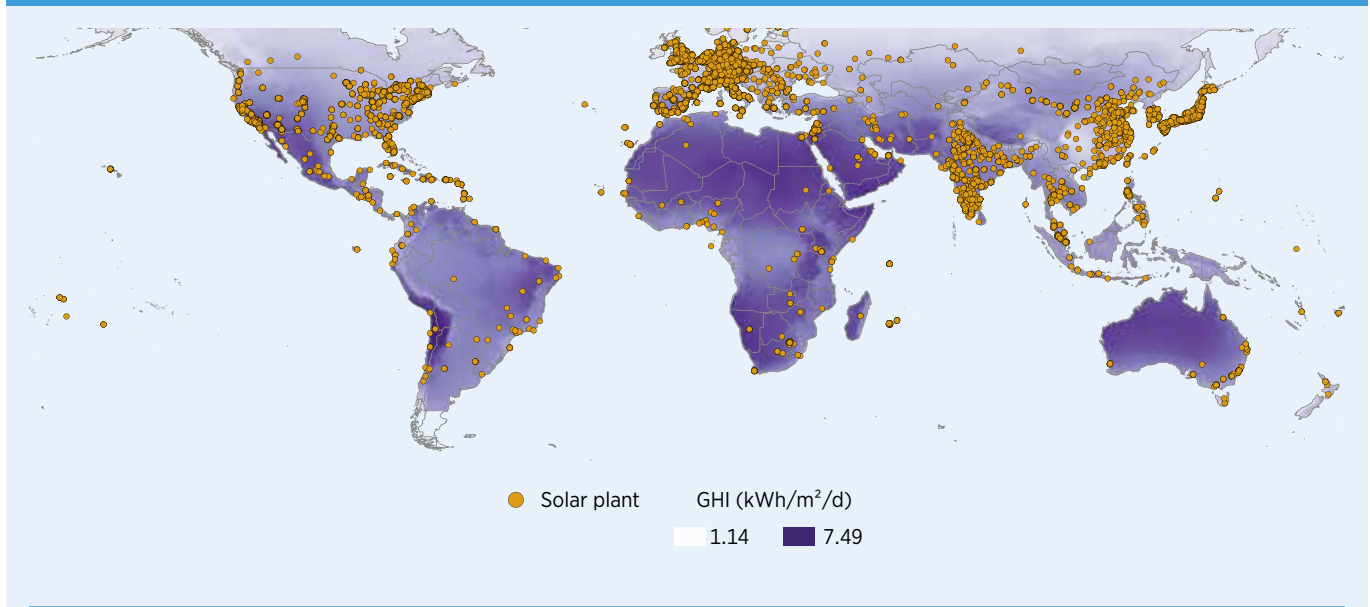

Based on IRENA analysis  
 Disclaimer: Boundaries and names shown on this map do not imply any official endorsement or acceptance by IRENA.

This suggests that solar PV power plants for cities can be justified even in areas that have less-favourable solar resources. Non-technical factors – such as the political ambition of local governments, growing electricity demand driven by strong economic activity, supportive policy and regulatory frameworks, and public acceptance – play a key role in scaling up solar PV applications in cities. Moreover, the analysis indicates that economies of scale are a comparatively minor consideration for solar PV plants near load centres.

For cities, it therefore makes sense to opt for decentralised solar PV systems that can be integrated in new and existing buildings, especially in densely populated urban areas where space for utility-scale plants is scarce. Increasingly, digital technologies and other innovations can help distribution system operators and utilities monitor, operate and control such assets. Additional advantages of decentralised systems – such as the avoidance of long-haul electricity transmission and the modularity of PV power plant configuration – can easily offset the scale factor, allowing local PV plants to perform well at smaller scales (Skalik and Skalikova, 2019; Dhimish *et al.*, 2018).

In the Middle East and North Africa region, the solar energy resource potential (particularly the direct solar irradiance) is excellent. For example, the United Arab Emirates (UAE) has a GHI of 6.5 kWh/m<sup>2</sup> per day, averaging 10 hours of sunlight daily over 350 sunny days in a typical year (Masdar Institute and IRENA, 2015).

Given the large desert area, land availability rarely presents a challenge, which is a key reason that utility-scale solar leads renewable energy deployment in the region.

Nonetheless, oil- and gas-producing countries in the region are increasingly giving greater attention to distributed solar energy in their efforts to diversify the energy sector. By 2019, Dubai had a total of 125 MW of distributed solar PV installations at 1 354 sites, according to the Middle East Solar Industry Association (Publicover, 2020). Solar energy applications will likely expand in response to the UAE's commitment, made at the 2019 UN Climate Summit, to achieve zero carbon emissions from all buildings by 2030.

In contrast, Africa, which boasts one of the world's highest average GHIs at 5.815 kWh/m<sup>2</sup>/day, is home to only 1% of the solar power plants located near cities. This is because of the region's low urbanisation rates and the lack of electricity infrastructure to support the integration of VRE sources, in addition to other barriers. Africa's large solar resource remains largely unexploited.

Although attention and activities around solar energy development have grown on a national scale (DIE, 2020), strategic thinking could help reconcile renewable energy development with the ongoing urbanisation process. If African countries can plan their exploitation of the region's vast solar potential (alongside other clean energy sources) in concert with urbanisation – and if they can plan the development of power grids in concert with the economic growth driving energy demand – then urban energy development in Africa would leapfrog along a renewable rather than a fossil-based trajectory.

## WIND POWER

**Good wind resources are often available in or around cities.**

*Wind energy resources near cities*

With the emergence of innovative turbine designs, the ability to harness wind power in the built environment is progressing fast. Yet urban wind deployment in actual practice remains marginal and rare. However, the deployment of smaller-scale wind farms or just a few wind turbines in peri-urban areas is growing, particularly in wind-abundant regions.

Using the power density at a 100-metre hub height as an indicator for wind power potential near cities<sup>7</sup>, the analysis done for this report found that many of the cities that have renewable energy targets in areas with high wind energy potential.

Innovative turbine designs could facilitate greater urban wind use.

In places where no transmission lines exist or where no current transmission capacity can be used, a dedicated line could be economically justified to connect potential wind farms with load centres, given the limited transmission distance<sup>8</sup>.

The analysis found that 151 of the cities that have renewable energy targets, or 40% of the total, are in the top 30% for high wind potential (Table 2). Of these cities, 86% have targets for 100% renewable energy. These ratios are even higher for the top 10% of cities with the highest wind potential.

<sup>7</sup> The assessment was conducted based on the Global Wind Atlas (Global Wind Atlas, 2019).

<sup>8</sup> In this study, a 50-kilometre radius is applied.

**Table 2: The number of cities with high wind potential in each dataset**

Percentile	Power density (W/m <sup>2</sup> )	Studied cities (dataset)	Number of cities with renewable energy target	Number of cities with 100% target
Top 10	607.0	57	29	26
Top 20	457.7	206	88	80
Top 30	381.5	394	151	130

Based on IRENA analysis

Most of the cities with targets and that are in the top 30% for wind energy potential are located Europe (Figure 10). However, more than half of the studied cities with good wind energy potential have not yet set a renewables target of any kind.

This deserves further investigation, especially if accompanied by a map of wind and solar resources combined. In many locations, wind power may be complementary to solar power, given the temporal distribution characteristics of these resources.

Figure 10: **Cities in the top 30% for wind power density vs. cities with renewable energy targets**

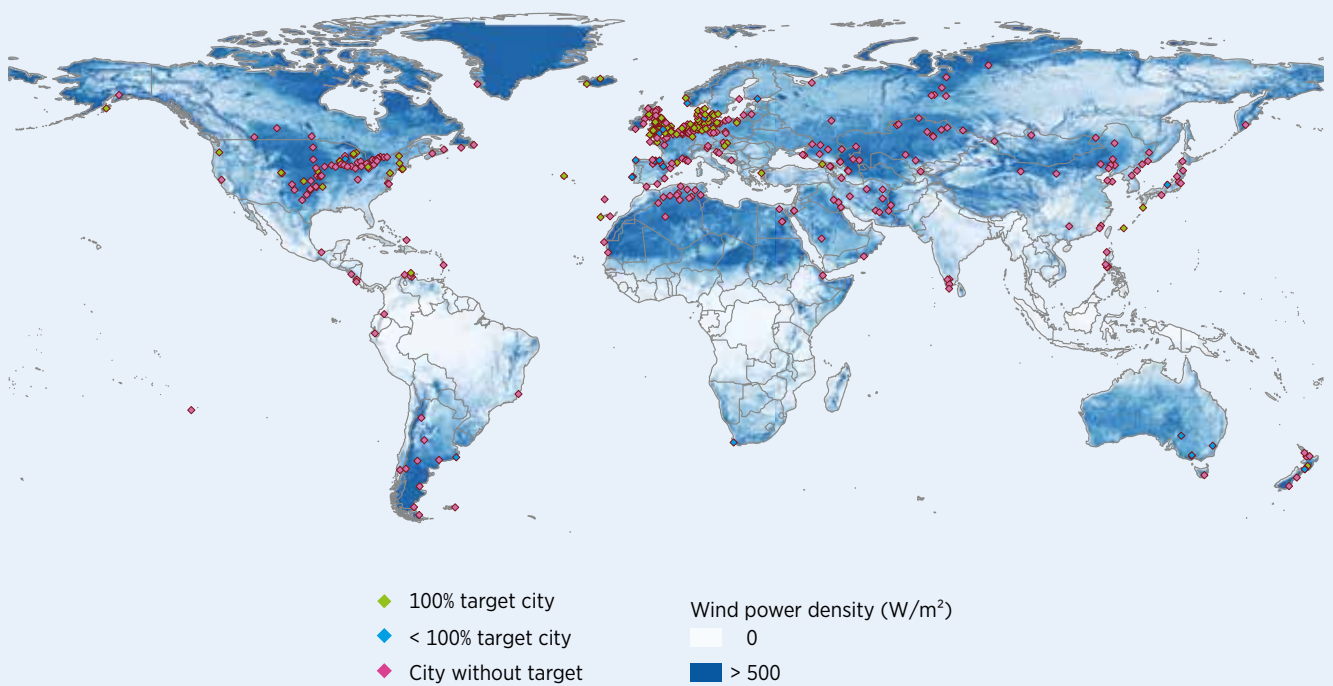

Based on IRENA analysis

Disclaimer: Boundaries and names shown on this map do not imply any official endorsement or acceptance by IRENA.



*Wind power plants near cities*

Of the 14 652 wind power plants located near cities, 27% have a power density in the range of 350–500 watts (W) per m<sup>2</sup>, and 23% have a power density in the range of 500–650 W/m<sup>2</sup> (Figure 11).

Nearly three-quarters of the plants are in Europe, but they represent only 44% of the total installed generation capacity, indicating a lower average generation capacity per plant.

Figure 11: **Distribution of wind power plants near cities by power density and region**

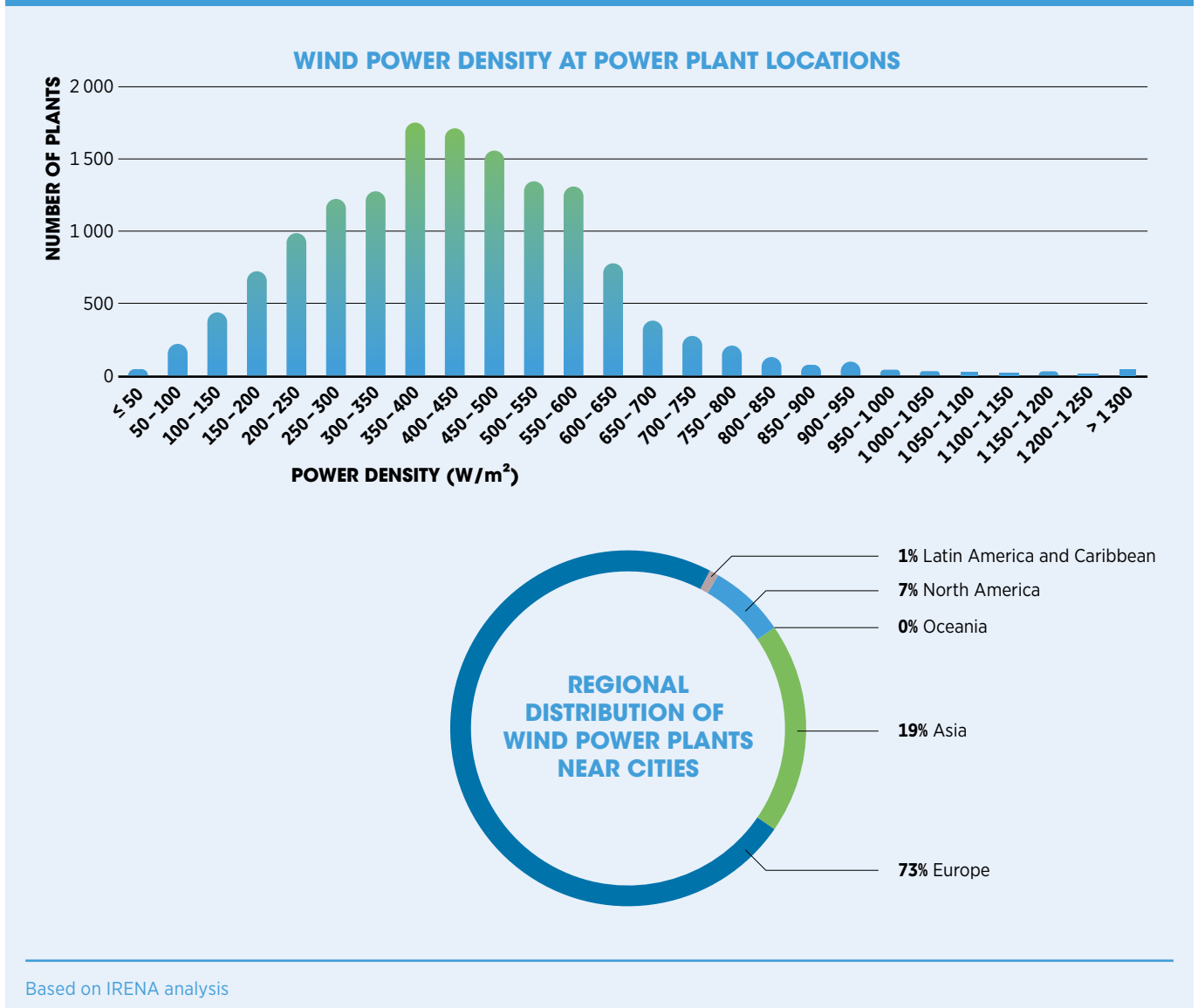

Asia, in contrast, is home to just one-fifth of the total plants but represents 32% of the total capacity.

China's eastern coast and on India's western coast (Figure 12).

In Asia, the average generation capacity per plant is 43 MW, compared to 14.5 MW in Europe, due likely to the much greater energy demand at the city level in China and India.

Given that nearly half of the cities worldwide that have renewable energy targets in are Europe, and that coastal cities in the US, China and India are generally economically advanced, wind generation near cities would arguably make a greater contribution to the provision of clean energy to these cities.

Geographically, a high concentration of wind power plants is in Europe, in coastal areas of the US, along

Figure 12: Power density and geographic distribution of wind power plants near cities

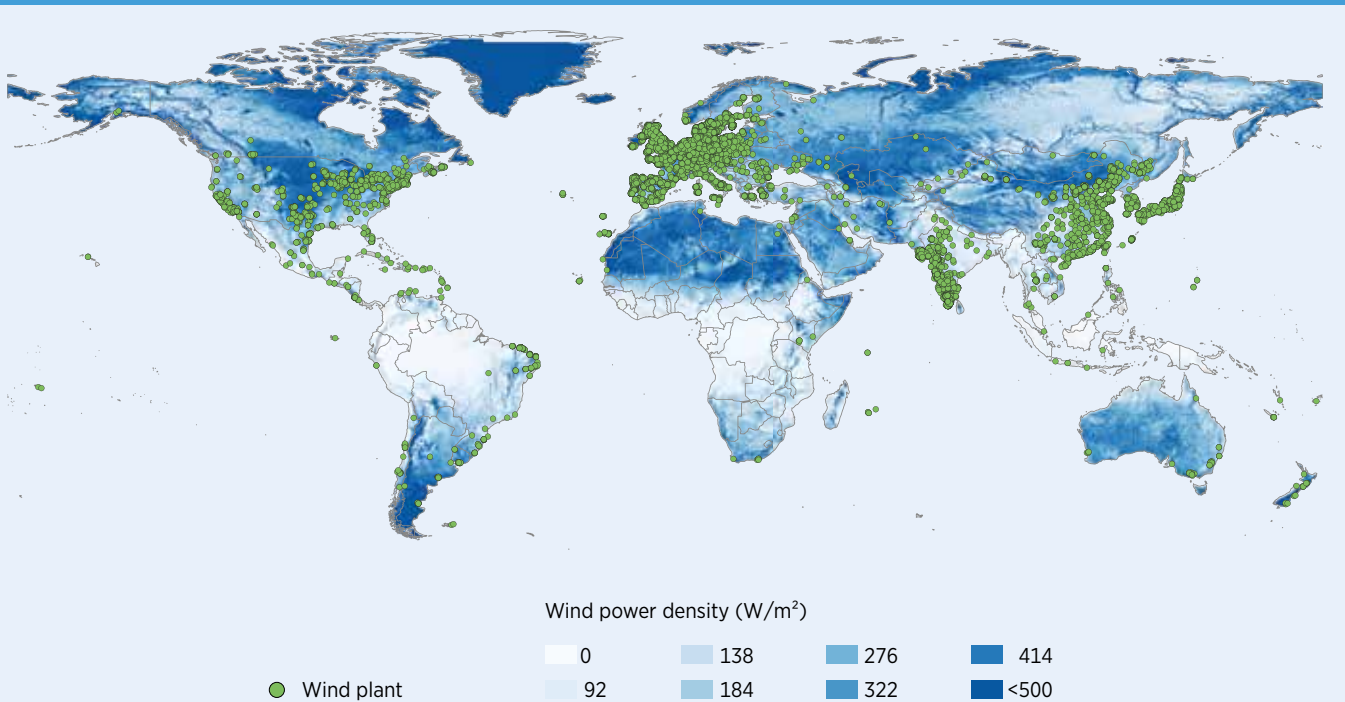

Based on IRENA analysis

Disclaimer: Boundaries and names shown on this map do not imply any official endorsement or acceptance by IRENA.

## HYDROPOWER

### Hydropower contributes to achieving city renewable energy targets and decarbonising the energy mix.

Hydropower is part of the power mix in 275 of the cities identified in the CDP database. In 43% of these cities, hydropower accounts for 25% or more of the installed generation capacity, and in 30 cities it is the only source for power generation. Among the 43 cities that report being 100% powered by renewable energy, 26 are in Brazil, a country where hydropower supplies more than three-quarters of all electricity (CDP, 2019b).

This suggests that a city’s accessibility to nearby hydropower may facilitate the local government to set renewable energy targets.

Globally, the cities that have renewable energy targets are located nearer to river segments that show hydropower potential above the global average, as measured by the median hydropower potential (kWh/year) (Table 3).

On average, the hydropower plants located near cities in Europe and North America have a smaller capacity than those in Asia and in Latin America and the Caribbean (Figure 13).

Hydropower helps to decarbonise the energy mix and meet city-level renewables targets.

Table 3: Median distance to nearest river segment and segment power for each dataset

	Studied cities (dataset)	Cities with renewable energy target	Cities with 100% target
Median hydropower potential (kWh/year)	165 563	233 015	226 884
Median distance to river (m)	2 070	1 462	1 385

Note: Hydropower potential was calculated for global river basins by Hoes *et al.* (2017) based on the slope and discharge at each location. This dataset is spatially discontinuous due to the nature of river basins. Instead of finding the potential at each point, the distance to and the hydropower potential at the nearest potential location was found for each city and hydropower plant.

Based on IRENA analysis

Figure 13: **Distribution of hydropower by region**

**HYDROPOWER GENERATION CAPACITY NEAR CITIES BY REGION**

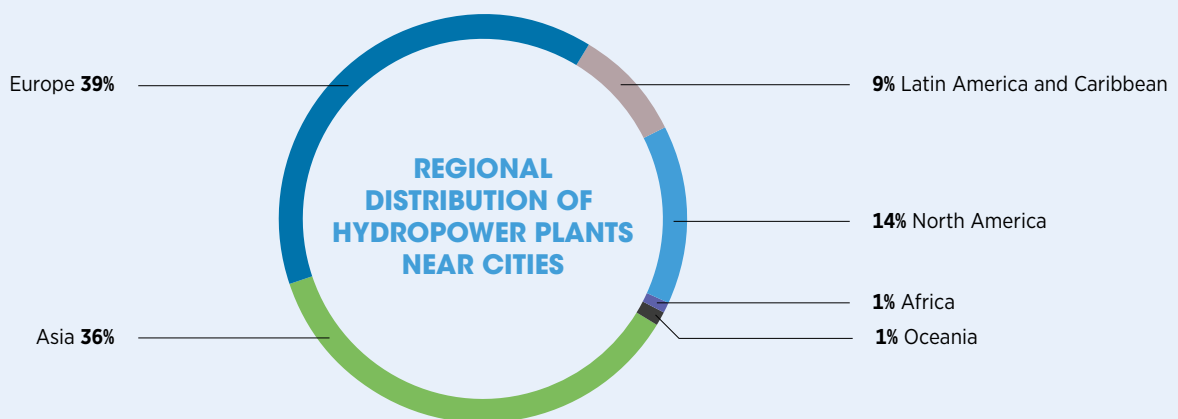
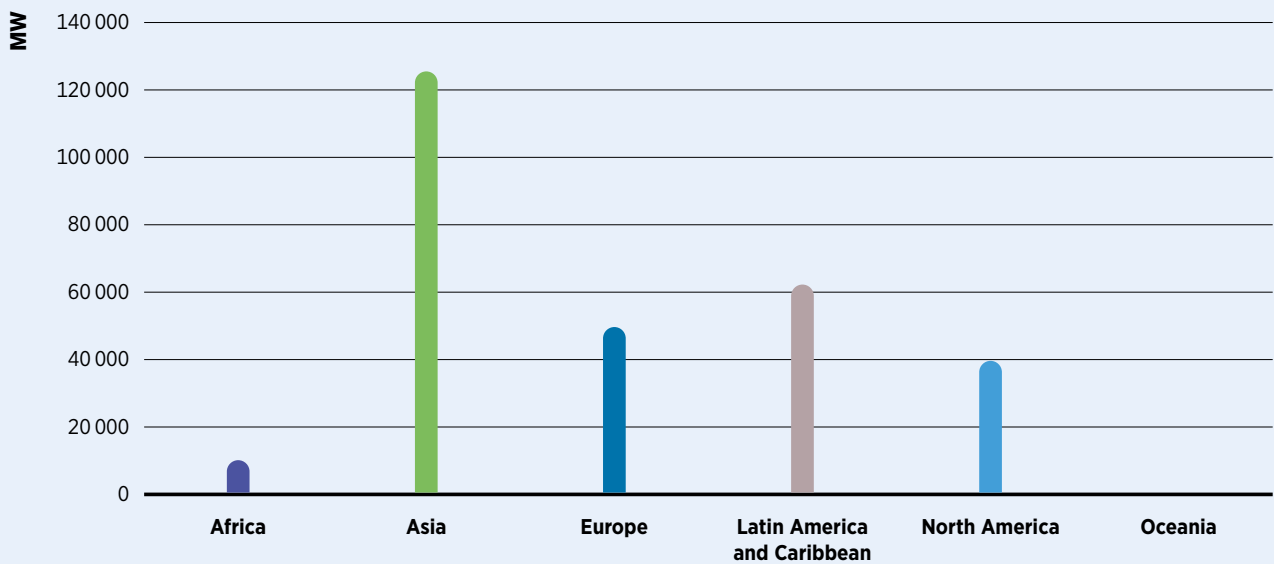

Based on IRENA analysis

### BIOENERGY AND WASTE-TO-ENERGY

**Bioenergy and waste-to-energy can provide multiple benefits for cities.**

Modern use of biomass residues or energy crops, and of waste-to-energy, can provide reliable energy supply and generate multiple benefits for cities, provided that the feedstock is well managed. Worldwide, more than 6 000 biomass-based power plants and around 3 000 waste-to-energy generation facilities in or near cities.<sup>9</sup> European cities have the most such facilities, with 55% and 59%, respectively, of the two types, followed by Asia and North America (Figure 14).

Coupling agricultural and urban waste with energy infrastructure offers multiple benefits.

<sup>9</sup> Using a radius of 50 kilometres from the city centre.

Figure 14: **Bioenergy and waste-to-energy plants by region**

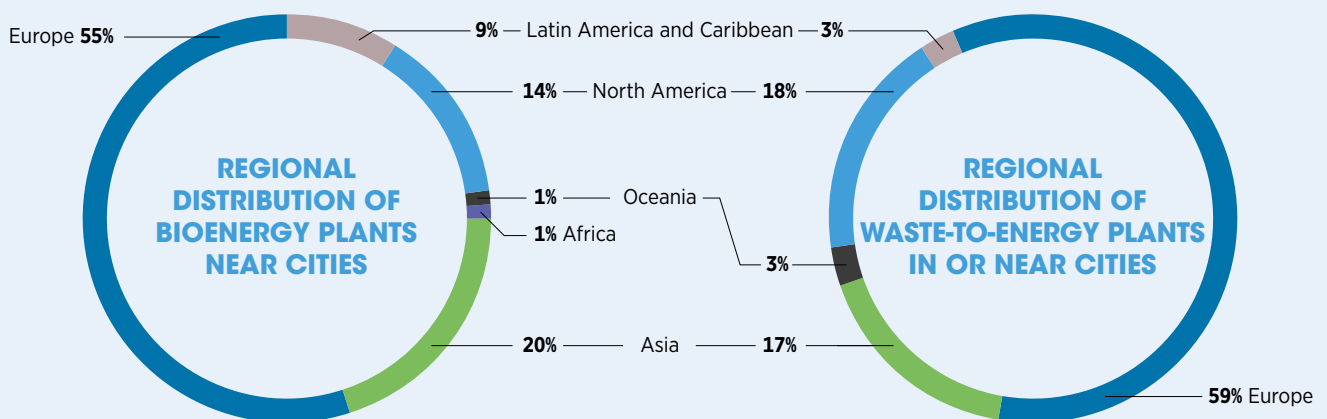

Based on IRENA analysis

The US leads North America in biomass-based power plants, while in Asia these plants are concentrated in Japan, along China's east coast and in India (Figure 15). By comparison, waste-to-energy facilities appear to be widespread in all regions (Figure 16) because wastes are available in all cities and have increased over time, challenging urban waste management systems around the world.

Many cities have embraced such facilities regardless of whether the city has a renewable energy target. One tonne of waste is roughly equivalent to 500 kWh of electricity (Porteous, 2005).

Currently, 70% of municipal solid waste goes to landfills or to uncontrolled dumpsites, while inorganic materials such as metal, plastic and glass are collected or recycled to varying extents.

Waste-to-energy helps cities avoid the water and soil pollution and greenhouse gas emissions that result from waste disposal, while generating energy in the process (Mavropoulos *et al.*, 2012). (For more on biomass technologies and applications, see chapter 3.)

In developing countries, particularly those in Africa, traditional use of biomass remains common, contributing to environmental and health challenges such as deforestation and indoor air pollution. Although biomass accounts for a large share of the region's energy mix, Africa is poorly represented in both biomass power plants and waste-to-energy facilities.

Modernising the use of residues and planting dedicated energy crops near cities may offer a promising solution. Similarly, as part of the urbanisation process, African cities could build and improve their municipal waste management in conjunction with waste-to-energy technologies (Edo and Johansson, 2018). According to one estimate, in 2025 an estimated 2 562 petajoules of energy could be generated from all waste, including landfill gas, in Africa (Scarlat *et al.*, 2015).

Figure 15: **Global biomass power plants near cities and cities with high resource potential**

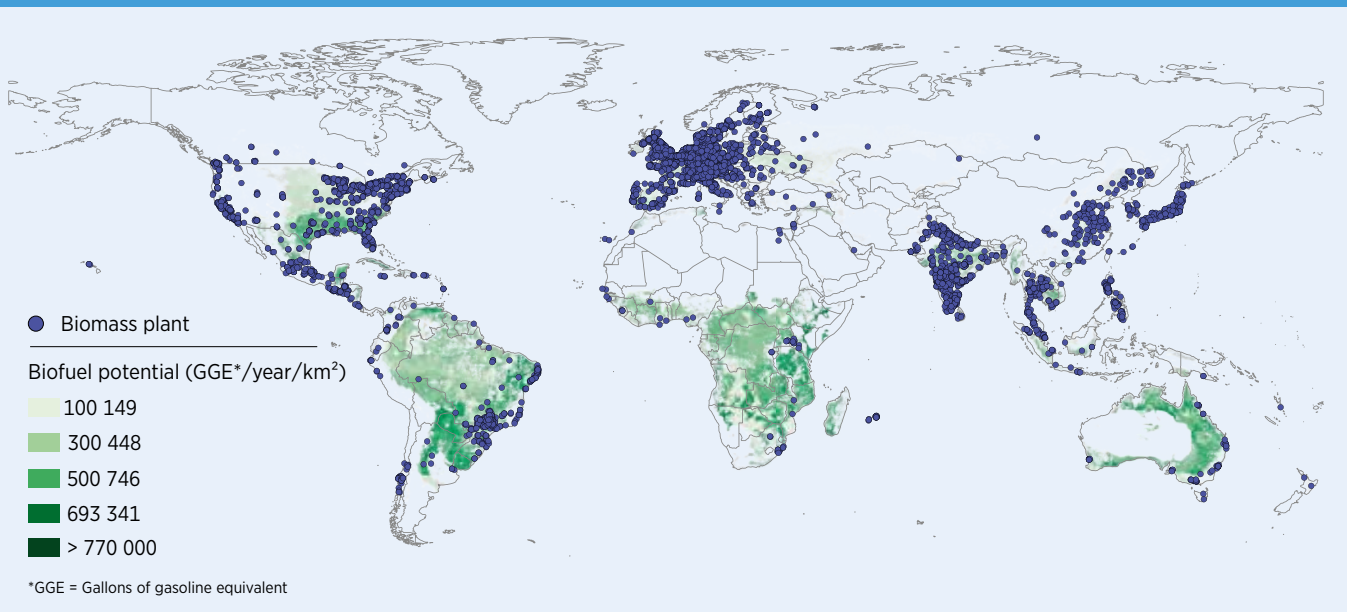

Based on IRENA analysis

Figure 16: **Global waste-to-energy plants near cities**

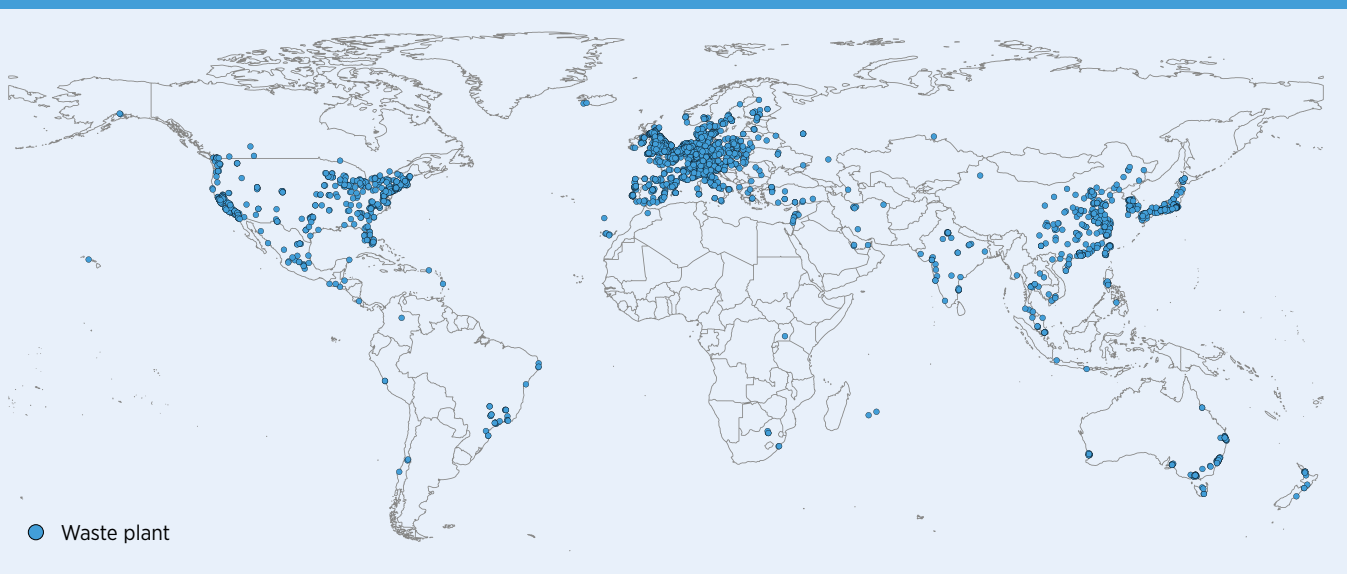

Based on IRENA analysis

Disclaimer: Boundaries and names shown on these maps do not imply any official endorsement or acceptance by IRENA.

## GEOTHERMAL ENERGY

**Untapped geothermal energy resources are available beneath the urban surface for direct use.**

Surface heat flow can be used as an indicator for geothermal potential; however, further exploration is needed to more accurately estimate the geothermal potential at considered sites. For this analysis, heat flow data were downloaded from the resource assessment by Davies (2013). Using the methodology of Limberger *et al.* (2017), volcanic data (Global Volcanism Program, 2020) were then included on top of the heat flow measurements. Active volcanoes were given a heat flow of 140 million watts per m<sup>2</sup> (W/m<sup>2</sup>), and dormant volcanoes were given a heat flow of 80 million W/m<sup>2</sup> (Nagao and Uyeda, 1995).

In addition to the natural surface heat flow affecting geothermal potential, thermal energy is often observed to be higher beneath the built environment than in rural areas, a phenomenon known as the sub-surface urban heat island effect. This increases the potential for geothermal energy but also increases the complexity in estimating it.

Untapped geothermal energy underneath the city may be available for direct use.

A clear relationship does not appear to exist between geothermal energy potential and renewable energy target setting in cities (Table 4). Unlike for most other renewable energy resources, accurate assessment of geothermal energy potential is complex and costly. Existing legislative, regulatory and environmental rules also could hamper the development of geothermal energy projects. These factors limit the role of geothermal in city renewable energy targets. Currently, only five cities specify the use of geothermal in their targets.

**Table 4: The number of cities with high geothermal potential in each dataset**

Percentile	Surface heat flow (MW/m <sup>2</sup> )	Studied cities (dataset)	Number of cities with renewable energy target	Number of cities with 100% target
Top 10	80.00	658	129	76
Top 20	66.75	1 416	243	140
Top 30	63.00	1 900	293	165

Based on IRENA analysis



In total, 69 geothermal power plants, or more than 60% of the global installed capacity, were identified as being within a 50-kilometre radius of a city centre, based on a database from the International Geothermal Association<sup>10</sup>. Most of the plants in Asia (39%) and North America (32%) (Figure 17), and these regions account for 43% and 28%, respectively, of the total geothermal power generation capacity.

This suggests that the average generation capacity per plant in these two regions is broadly similar, due mainly to the larger size of geothermal power plants required for economic viability.

Given that the plants are located near cities, most are likely configured as combined heat and power (CHP) plants to achieve higher energy efficiency through cascading applications (often in connection with district heating networks) and economic performance.

Compared to geothermal power generation, direct use of geothermal energy is a much more accessible resource, with an estimated global technical potential more than 100 times that of geothermal power (Hoogwijk and Graus, 2008). Direct use of geothermal, often in conjunction with heat pumps, can take advantage of lower-temperature geothermal energy to meet the demand for heating and cooling; it accounts for roughly half of the global geothermal energy output (Lund and Toth, 2020).

10 See Geothermal Power Database, [www.geothermal-energy.org/explore/our-databases/geothermal-power-database](http://www.geothermal-energy.org/explore/our-databases/geothermal-power-database).

Figure 17: Distribution of geothermal power plants near cities by region

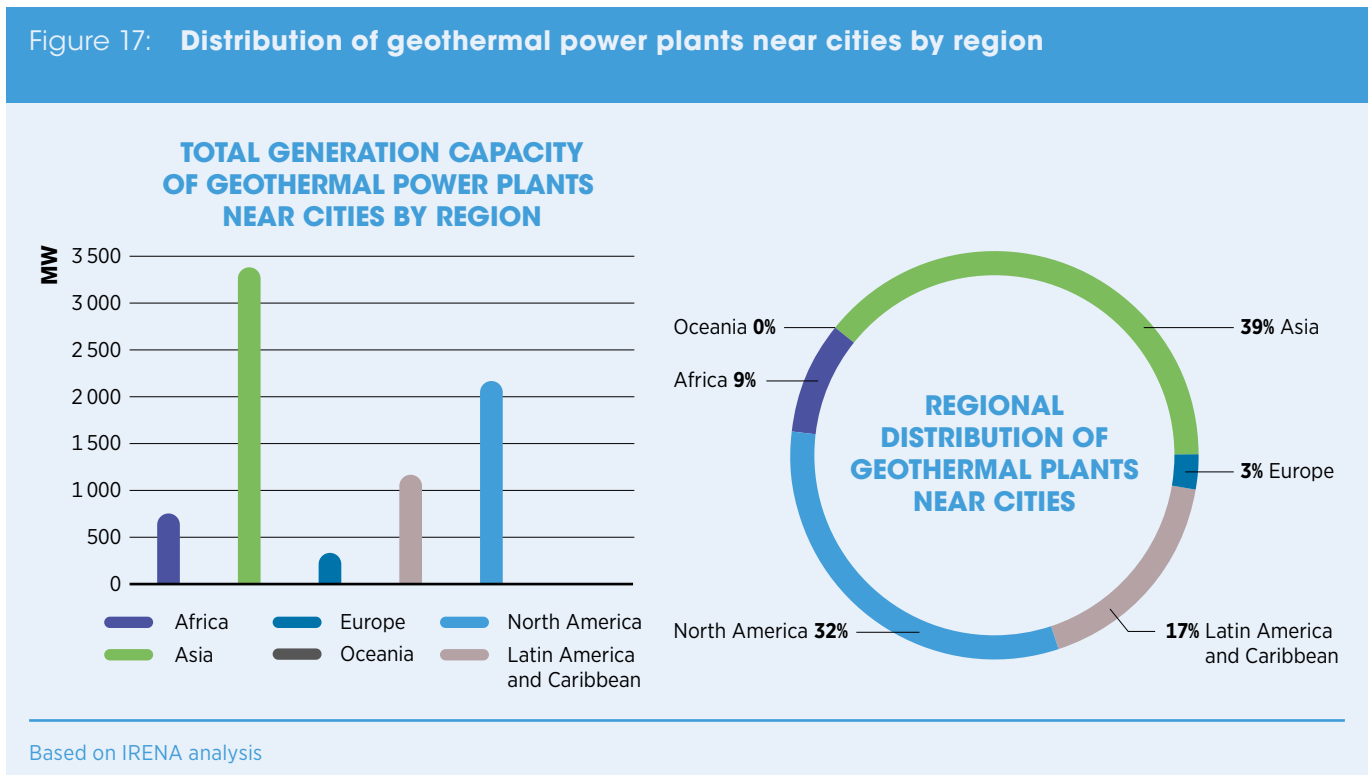

## SUMMARY REMARKS

Overall, cities show notable potential within their immediate jurisdictions to develop one or more renewable energy resources. Regardless of whether they have set renewable energy targets, cities should assess these potentials both technically and economically, as the deployment of renewables brings more than just physical energy carriers, but also many co-benefits.

For cities that have high renewable energy ambition, a target could send a clear signal to the market and thus attract greater investment, especially when accompanied by a legislative framework and when administrative procedures are in place. Careful local renewable energy assessment that leads to developable projects would encourage investors and project developers to direct further resources towards urban renewable energy deployment.

For cities behind the curve, if they have abundant renewable energy resources and expect growth in their energy demand, tapping into such potentials could bring significant long-term gains through technological leapfrogging.

Greater communication among city, provincial/state-level and national governments is required to align renewable energy ambitions and improve knowledge sharing. In regions where renewable energy targets are uncommon, such as Africa and Central Asia, national governments and international initiatives will be key to motivate cities to set targets and to give them the tools and information to achieve them.

Lastly, efforts to maximise the use of local renewable energy resources by no means preclude the purchase of renewable energy commodities (such as renewable electricity) from other regions. In most cases, locally available renewable energy is inadequate to fully supply the energy demand of cities, necessitating additional energy from outside the city boundaries.

Given these challenges and opportunities, a clear strategy for renewable resource use must be integrated into city planning. This is essential to create a clear pathway for the transition of the urban energy system to a low-carbon, sustainable and climate-resilient future. (For more on urban energy planning, see chapter 4.)

3.

**URBAN RENEWABLE  
ENERGY TECHNOLOGIES**

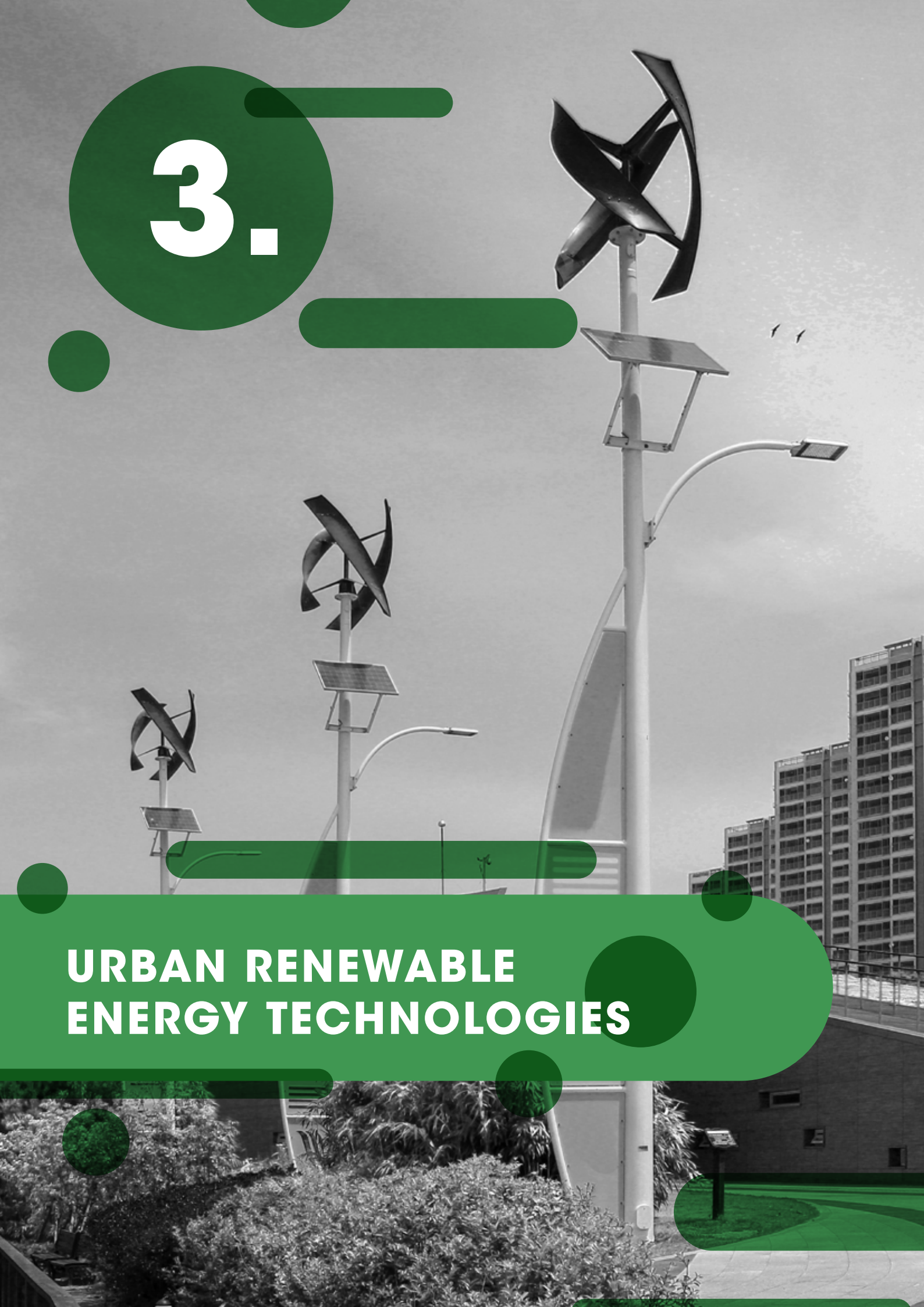

## 3. Urban renewable energy technologies

The integration of renewable energy technologies in cities faces various challenges, including legislative, policy, regulatory, financing, human capacity, aesthetic, design and urban planning barriers. A suite of instruments – including renewable energy procurement, ordinances and mandates – serve as effective policy measures to address these challenges, as identified in a set of case studies in *Scaling up renewables in cities: Opportunities for municipal governments*, published by IRENA in collaboration with ICLEI and the German Agency for International Cooperation (GIZ) (IRENA *et al.*, 2018).

To some extent, these barriers also result from a lack of awareness of the opportunities and benefits of harnessing locally available renewable energy resources (such as enhanced energy security and the creation of local job opportunities), from a lack of knowledge of renewable energy applications in cities, and in some cases from a lack of public acceptance of power plants in or near cities. This chapter aims to equip technology providers, energy system planners and municipal decision makers with key knowledge around these aspects.

### 3.1 Solar energy

Two types of conversion technologies<sup>11</sup> exist for harvesting solar resources to produce energy: photovoltaics (PV) to generate electricity, and solar collectors to produce thermal energy. Both can be applied at various scales and can operate via a stand-alone or grid-connected configuration. While solar PV provides only electricity, solar thermal has many different applications suitable for urban areas. This section describes the existing technological solutions often used for urban areas, such as PV systems, building-integrated PV (BIPV), various solar thermal technologies (including concentrated solar thermal systems) and solar photovoltaics-thermal (PV-T).

---

<sup>11</sup> Passive solar energy has also been widely used but is excluded in this study.

### URBAN SOLAR PV

The global installed capacity of solar PV has increased rapidly over the past decade, from around 40 GW in 2010 to 580 GW in 2019 (IRENA, 2020c). Most of this is utility-scale solar power plants, although in some countries, such as Germany, smaller-scale distributed solar PV systems in and around cities have dominated deployment.

Within cities, solar PV systems are usually installed on, or integrated with, the roofs and façades of buildings. These systems are generally smaller in scale than ground-mounted systems located on the outskirts of cities.

The median size of installed residential PV systems in 2018 was around 6.4 kilowatts (kW), which was 8% larger than in 2014 due primarily to falling costs (Figure 18).

The key technical advantage of residential systems is their proximity to the load, which avoids the energy losses and wheeling charges associated with long-distance transmission. However, cities are also increasingly recognising the many social and environmental co-benefits that these systems provide, including greater resilience to extreme weather events and the impacts of climate change.

Figure 18: **Global median installed residential solar PV system size**

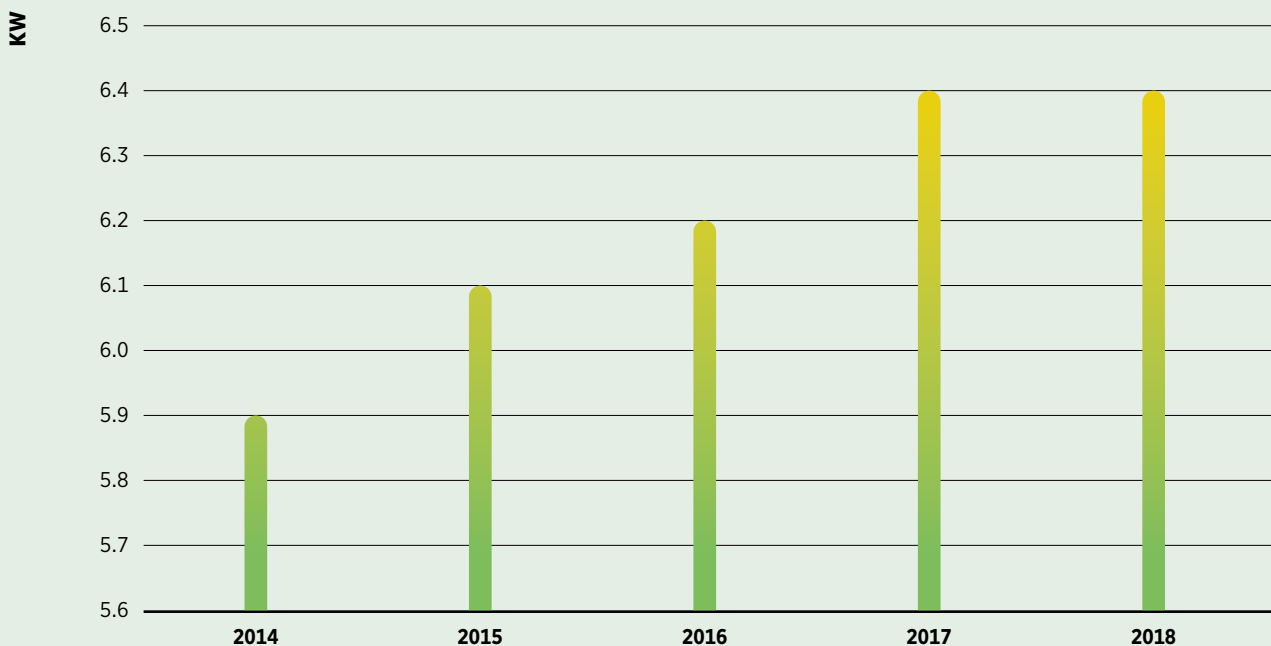

Source: Data from Barbose and Darghouth, 2019

Despite the many advantages that solar PV systems bring to cities, unique challenges exist to scaling up PV applications in urban areas.

First and foremost is the land constraint. In most cases, either cities do not have the available land suitable for on-ground solar PV plants due to competing uses such as agriculture or ecological reserves, or the cost of the land is prohibitively high.

For this reason, integrating solar PV systems into existing or planned urban buildings or other infrastructure will continue to be the preferred practice. However, examples exist of on-ground solar PV plants (usually community or city owned) that are installed on the outskirts of cities as part of actions to achieve political commitments, for example in co-operation with rural communities (Energy Cities, 2018).

Secondly, most cities are concerned about the impact of integrating VRE sources, such as solar PV, on grid operations, as this can create challenges for utility operators in managing the urban electricity system and can affect grid stability. When the share of solar PV increases to a certain level for a given distribution power system, the impact on grid stability and the required grid flexibility can be examined by applying computer-based simulation tools such as PowerFactory<sup>12</sup> and FlexTool<sup>13</sup>.

---

<sup>12</sup> PowerFactory is designed for grid connection and grid impact analysis.

<sup>13</sup> The IRENA FlexTool is aimed at analysing the flexibility needs of power systems. Its advantages include short calculation times and the ease of configuring the tool to analyse multiple alternative scenarios with various levels of integration of VRE such as solar PV.

The results can provide an improved understanding of the implications of different PV installation scenarios for grids, and of the measures available to offset adversities by enhancing grid flexibility. In addition, pilot projects are available worldwide showing that solutions that combine innovations in various dimensions can help integrate distributed resources into the grid. For example, aggregated solar PV plants coupled with batteries could help system operators by providing services to balance the system, as long as the necessary enabling technologies and support frameworks are in place.

Thirdly, local policy and decision makers need to better understand the economic implications of solar PV systems for local power suppliers and utilities. Innovative business models must be created to reconcile the interests of incumbents with those of emerging actors. These newcomers include prosumers who not only consume but also generate electricity (either for self-consumption or to sell back to the grid); aggregators who are grouping multiple new players in the power system to participate in the market activities as if they are one single player; and peer-to-peer traders who aim to maximise the economic return on investment in the individual distributed energy generation facilities (IRENA, 2019a; IRENA, 2019c).

**Rooftop solar PV**, the most popular renewable technology choice in cities, faces inherent technical limitations and challenges. These include the limited per capita rooftop space for energy generation in densely packed urban environments, the unfavourable conditions of roof structures, unexpected shading losses and unqualified installations.

Nonetheless, rooftop PV systems remain a promising solution in cities, and a growing number of tools have been developed to help local authorities and other stakeholders assess the policy and financing options for rooftop generation. IRENA's SolarCity Simulator, for example, can be applied at scales ranging from single-rooftop assessments at the household level to aggregate-level analyses undertaken by municipal authorities and other large entities (IRENA, 2019f).

Beyond rooftop PV, the next generation of urban solar technologies and products is emerging that aims to more fully capture the solar energy potential, especially on new and planned buildings. The goal is to turn PV from an electricity generator into a type of building material that can generate power but can also be used to build the urban fabric. Building-integrated PV is one form of this.

**Building-integrated PV (BIPV)** involves two major product categories: façade-integrated (such as PV wall/façade) and roof-integrated (such as PV shingles and tiles). Transparent and semi-transparent façade-integrated BIPV can be a good solution for buildings. To ensure success with these solutions, both transmittance and the window-to-wall ratio must be designed correctly to maximise generation (NC State University, 2018).

For vertically installed façade-integrated BIPV, the peak electricity generation will be different than for most roof-mounted systems, thereby smoothing out the output curve from the entire PV system in a building.

Solar PV shingles and tiles for roofs can be used to provide building structure while also generating power, especially for constructions where conventional PV systems would not be possible. These products also can be aesthetically pleasing and easier to install, and they generally require less maintenance; moreover, replacing a single tile is less expensive than replacing a whole panel.

Other BIPV technologies in development include adaptive solar façades and tracker technologies. These technologies track the path of the sun throughout the day and adjust their angle accordingly, thus increasing efficiency. Compared to fixed BIPV technologies, they can enable higher generation in the same area (Nagy *et al.*, 2016).

However, BIPV is still in the initial stage of technology development and needs to overcome a variety of market and technological barriers. Despite its 60% decline in costs from 2004 to 2015, BIPV remains more expensive than conventional PV systems (Maturi and Admi, 2018; EASME, 2019). The main issues in evaluating BIPV include the overall system conversion efficiency, the flexibility in design, and the endurance and lifetime as a power generation technology.

Additional issues relate to the construction material, temperature co-efficiency and thermal properties, stability and degradation over time, safety and cost effectiveness, as well as the lack of harmonised technical standards and qualification procedures for performance assessment and validation (MIT, 2015; SUPSI *et al.*, 2019).

## SOLAR THERMAL ENERGY

In general, solar thermal systems can be used for heat as well as electricity supply. The sun's heat is typically converted to electricity through CSP technology, which usually operates at a large scale to make it economically viable, thus requiring a large land area. However, most CSP plants are installed far from cities in locations that have excellent direct solar irradiance. Their application (and relevance) to cities is limited, except for concentrated solar thermal technologies used for district heating systems or industrial facilities within the city boundaries.

In contrast, non-concentrated solar thermal systems, used primarily for supplying heat, can be used at smaller scales that demand less space, and therefore are often installed in urban areas. This technology comprises solar thermal collectors that absorb and convert the solar radiation to heat, with efficiencies of up to 80% depending on the operating temperature (Tripanagnostopoulos, 2012).

Three types of solar collectors are commonly used for individual or stand-alone systems in cities: flat plate and evacuated tube collectors (to produce temperatures of 120 °C and below) and low concentrating collectors (120 °C and above up to 200 °C) (Weiss and Rommel, 2008). Each technology has advantages and disadvantages, and the choice depends on the required temperature and other criteria. Solar thermal systems have long been adopted to provide water and space heating for buildings, but they can also generate industrial process heat. In cities, these systems can be placed on roofs, façades, balconies and any outside building area.

The heat collectors also can serve as insulation in the building envelope, thereby reducing the heating and cooling demands (Maurer *et al.*, 2017; Li *et al.*, 2015; Mohajeri *et al.*, 2016; Huide *et al.*, 2017).

**Solar water heating systems:** For countries at lower latitudes, an individual solar hot water system can cover up to 100% of residential demand (Mathiesen and Hansen, 2017). At higher latitudes that have large seasonal variation in irradiation, the systems can provide only 20–60% of the heat demand for domestic water and space heating in the absence of a seasonal storage system (IEA Task 55, 2019).

For commercial and service buildings that have high and constant thermal demand, such as hotels, hospitals and shopping malls, such systems are often used to achieve cost savings and/or to demonstrate corporate social responsibility. In California, the average share of water heating that solar thermal can provide is 70–80%, with a seasonal range of 25–90% (Hopkins *et al.*, 2018).

A growing number of cities and countries have adopted mandatory use of solar water heaters for all new buildings as part of the building code. China, with an installed solar water heater capacity of 337.6 gigawatts-thermal ( $\text{GW}_{\text{th}}$ ), or 70% of the world total, remains the biggest market for the technology, while Europe is the second largest market, with one-sixth the installed capacity of China (Weiss and Spörk-Dür, 2019).

In countries where natural gas is cheap and is the dominant heating source, solar thermal systems are less competitive in the absence of incentives or promotional schemes to support their social and environmental benefits (Rosas-Flores *et al.*, 2016; Wang *et al.*, 2015; Sadhishkumar and Balusamy, 2014).



**Solar district heating:** In this application, large solar collectors deliver the produced heat via district thermal networks. Solar district heating was enabled by the transition of heating networks towards low-temperature (below 60–70 °C) district heating systems, known as the fourth generation. The solar system can be installed on the ground or on a building roof to supply heat for the building, community, district or city. The share of solar district heating ranges between 10% and 50% of the total heat supply of the district heating system (Pauschinger, 2016).

The system can be configured in combination with a storage facility (such as seasonal thermal storage) to provide heat whenever needed. Because of the scale of these systems, they normally have lower specific investment costs than smaller applications.

Europe has taken the lead with hundreds of solar district heating plants and a total capacity exceeding 1.1 GW<sub>th</sub> by 2019. Denmark, Austria, Germany and Sweden are the frontrunners, followed by other European countries, which are empowered by the EU's Horizon 2020 programme (SDH, 2019). The main benefits of solar district heating are that the system can be installed with low solar resources, provides a stable cost for at least 25 years, and uses already mature and available technology with zero emissions.

**Solar thermal cooling:** The applications of solar thermal energy have extended gradually into the cooling sector, coupled with absorption chillers. Because of the higher temperature required, evacuated tube or concentrating solar collectors that absorb direct radiation are usually adopted. In the most ideal conditions, solar cooling systems can reduce 50% of the primary energy required to produce cooling energy (Bellos *et al.*, 2016). To improve system efficiency and utilisation rates, a hybrid system seems to be more promising. In summer, solar thermal energy can be used for cooling, whereas in winter it can be used for space heating or hot water supply (Buonomano *et al.*, 2016).

A main advantage of solar cooling, apart from being a more environmentally friendly option, is the potential to lower peak demand on the grid during hot summers, reducing blackouts and the costs for grid enhancement (Lim, 2017). In Australia, the growing number of peak demand days over the country's hot summers has nearly doubled electricity consumption and pushed the peak load to the point of requiring grid enhancement. However, the marginal cost for grid enhancement to accommodate each additional air conditioning unit is estimated to be three times the cost of the unit, according to the country's Commonwealth Scientific and Industrial Research Organisation (CSIRO) (Lewis, 2016). Therefore, from a system cost perspective, it makes sense for solar thermal cooling to play a bigger role in the future.

Global cooling demand for buildings tripled from 600 terawatt-hours (TWh) in 1990 to 2 000 TWh in 2016 and is projected to at least triple again by 2050<sup>14</sup>. With economic and social development, cooling demand in the residential sector is expected to account for 70% of the total increase in cooling demand over the next three decades, and to surpass residential heat demand two decades later (IEA, 2018; Dreyfus *et al.*, 2020). With more cities positioned to scale up the use of renewables, renewable-driven cooling solutions are expected to be in high demand.

**Solar heat for industrial processes:** Solar thermal systems could provide heat for many industrial processes, such as chemicals, textile industries, food and agriculture, etc. Existing heating systems for industrial processes mainly use fossil fuels such as oil, natural gas and coal (IRENA, 2015d). Solar thermal systems can supply part of the heating demand of a plant depending on the solar resource availability and the size of the system. Usually, the system requires thermal energy storage or back-up fuel to prevent disruption when solar radiation is not available. The optimal system design could be simulated using one of several software options: TRNSYS, T\*SOL, POLYSUN and SOLTERM<sup>15</sup>.

An example of such a system is the COPAG system installed in Morocco, which uses 61 kilowatts-thermal of installed thermal power to supply heat at 80–90 °C for pasteurisation of dairy products<sup>16</sup>.

### SOLAR PHOTOVOLTAICS-THERMAL (PV-T)

PV-thermal technology is a hybrid system with integrated design and operation characteristics to provide both electric power and heat. The aim is to achieve higher overall energy conversion efficiency of solar radiation and address the challenge of limited available land area in cities. The contacting fluid can cool the PV panels for better electrical efficiencies during high summer temperatures, while the absorbed heat is used for direct heating.

New PV-T hybrid technologies include the use of air heaters to preheat the air and the use of nanoparticles and water as the base fluid (Al-Waeli *et al.*, 2017). Additionally, the Ecomesh second-generation hybrid solar panel is a rooftop solar hybrid system that is specially equipped with a transparent insulating front to avoid heat losses (Figure 19). The aim of the project is to supply the hot water needs of multiple apartment buildings (del Amo *et al.*, 2017).

---

14 See <https://climate.nasa.gov/vital-signs/global-temperature>.

15 To better understand the differences between the software and which one is better to use, see <https://task49.iea-shc.org/article?NewsID=246>.

16 For more examples and a database of all industrial heat solar systems, see <http://ship-plants.info>.

Another new development in solar PV-T hybrid systems is a module that produces electricity and is assembled with a heat recovery system. The heat recovery system is a layer on the bottom that produces hot water, while the solar PV still supplies the electricity (Nastasi and Di Matteo, 2016).

Because research on hybrid systems is still in its infancy, there remains an absence of knowledge about certain aspects. The high investment costs and the lack of knowledge and implementation of the systems remain the major barriers to potential market growth (Ramos *et al.*, 2017).

Figure 19: **Rooftop-mounted solar PV-thermal hybrid system**



Source: del Amo *et al.*, 2017

### 3.2 Bioenergy and waste-to-energy

For urban bioenergy use, the preferred feedstocks from both an environmental and logistical perspective are those made available locally. Local biomass for energy production can be derived from urban waste streams, such as municipal solid waste, sewage treatment plants and urban trees/forestry<sup>17</sup>, as well as from peri-urban agricultural and forestry areas, such as residues, firewood and waste from livestock farms located near cities. All these can be broadly categorised as biomass feedstocks for waste-to-energy (as opposed to the planting of dedicated energy crops). Waste-to-energy is particularly important for cities as it offers a practical means to incentivise waste recycling activities and to minimise the volume of wastes, whose environmental benefits can often be greater than those from energy recovery. For cities, the added value of urban bioenergy is three-fold:

- Bioenergy can provide a relatively reliable and consistent supply of energy thanks to the nature of bioenergy as stored energy, in contrast to solar PV or wind, which are variable renewables.
- Waste-to-energy offers a promising solution for urban waste management while at the same time generating energy for cities. It offers a pathway to a circular economy, particularly for the EU which has set 2030 targets for landfill reductions<sup>18</sup> (Ecoprog, 2018). Through combustion, the volume of urban solid wastes can typically be downsized by 85–90%, depending on the composition of the feedstock (Chaliki *et al.*, 2016; Rogoff and Screve, 2019).

- The combination of the above can in turn reduce emissions of greenhouse gases and other environmental pollutants.

Bioenergy applications have limitations, however. Guaranteeing a sustainable supply of feedstock can be challenging given the uncertainties in the waste management system and the limited collection radius for agricultural and forestry residues. Siting also can pose challenges related to the availability of land for large-scale waste-to-energy facilities and related to public acceptance, given the potential impacts on air quality and health (see below).

Addressing these issues will require coupling the energy sector and the waste management sector to ensure concerted actions. On-site conversion of raw biomass feedstock into wood pellets and briquettes through densification technologies offers an effective way to improve the economics of transporting the feedstock to urban consumers as well as to increase the quality of the feedstock for controlled and clean burning (IRENA, 2018). To boost public acceptance of waste-to-energy plants, both awareness and education as well as stringent environmental regulations are important. These aspects are crucial to the success of bioenergy applications in cities. However, they are beyond the scope of the current discussion and deserve their own separate analysis.

The key conversion technologies for urban waste-to-energy include direct combustion/incineration, anaerobic digestion and gasification. Through these means, the feedstocks are converted into energy sources such as thermal energy for direct use as a heating source, or into energy carriers such as electricity and biogas. Overall, such conversion technologies are well developed and have matured in recent decades.

<sup>17</sup> Urban trees/forests could also be part of the supply, using trees or branches that are dying or damaged from storms and insect and disease infection

<sup>18</sup> The Circular Economy Package states that landfilling of the biodegradable fraction of municipal solid waste (MSW) should be reduced by 65%, and the overall landfilling of MSW should be reduced by 90%. See <https://ec.europa.eu/environment/circular-economy>.

However, there is still a need for both technical and system configuration adjustments for different compositions of feedstocks, and the contexts of use are often necessary, given the advantages and disadvantages as well as cost profiles for different applications (WBA, 2016; Rogoff and Screve, 2019). Local fine dust emissions pose a challenge if the boilers are located within cities, and technologies to further reduce these emissions are under development. In the future, wood burning in cities could occur only in bigger boilers that supply district heating grids.

## DIRECT COMBUSTION/INCINERATION

Direct combustion technology, also known as incineration, involves burning waste biomass and the combustible inorganic fraction of the wastes in the presence of oxygen to produce steam. Large-scale incinerators often are used in conjunction with CHP or co-generation units that can deliver heat and electricity, thus achieving a higher system energy efficiency. In some cases, as with Sweden's Dåva plants, co-generation can also provide cooling energy through absorption chillers (Box 3).

### Box 3: District CHP and cooling systems in Umeå and Gothenburg, Sweden

Sweden banned the landfilling of combustible and organic wastes in 2002–2005, opting instead to divert the waste through recycling and incineration (Milios, 2013). With these stepped-up efforts, it has become the leading European country in waste-to-energy per capita, converting 7.6 million tonnes of waste into energy in 2017 (Crouch, 2019).

In the city of **Umeå**, the municipal utility Umeå Energi has operated two waste-to-energy CHP plants since 2000 and 2010 respectively. The Dåva 1 and 2 co-generation plants, located 9 kilometres north-east of the city centre, provide electricity as well as heating and cooling energy to urban residents through local energy networks. The facility uses domestic and industrial wastes, agricultural and forest residues, and other types of waste biomass as the primary feedstocks.

Use of the wastes, coupled with high system energy efficiency and very stringent emission controls, have made Dåva one of the most energy-efficient and environmentally friendly plants in the world.

With a total installed generation capacity of 175 MW, consuming around 1 000 tonnes of feedstock per day, the Dåva plants provide heat to nearly 50 000 average homes and supply electricity to more than 20 000 households annually. The plants also help the municipality address its growing waste challenge, in addition to facilitating the recycling of heavy metals and other materials from the bottom ash. Ultimately, the plants are driving Umeå forward to a circular economy.

---

Source: Smart City Sweden, 2020a; Umeå Energi, 2019

**Gothenburg**, Sweden adopted waste-to-energy as early as 1974. Over the past few decades, the city has built the capacity to turn the 345 000 tonnes of urban wastes produced annually from its municipal, industrial and commercial sectors into heat and electricity. This has helped Gothenburg avoid more than 200 000 tonnes of CO<sub>2</sub> emissions annually, or a quarter of the city's total energy-related CO<sub>2</sub> emissions.

A 2017 decision by the City Council is expected to extend the application of waste-to-energy to centralised district cooling. This will require substantial expansion of the network and the adoption of absorption chillers, taking advantage of existing waste-to-energy plants during the summer when their capacities are underutilised, as well as of free cooling resources such as the local river.

The system is scheduled to start supplying cooling energy to office buildings, hospitals and industries in Gothenburg by 2035.

Once built, the system will not only greatly decarbonise the city's cooling sector, but also lower the utility bills of end users using sustainable and renewable energy sources. This will also ease the peak-demand pressure on distribution power grids during hot summers by shedding the electricity load from conventional air conditioning units. Lastly, the municipal-owned utility, Göteborg Energi, will be able to generate clean energy from local renewables while also creating local job opportunities and bringing social and environmental benefits by achieving its fossil-free target.

Source: Smart City Sweden, 2020b; C40 Cities, 2011

Small stand-alone biomass boilers fed with wood pellets and briquettes, as well as modern wood stoves, are most commonly used to heat residential homes in developed countries. In contrast, traditional wood stoves are more typical for heating and cooking in developing countries, particularly in Africa (including in cities). Small-scale applications<sup>19</sup>, particularly stoves without flue gas cleaning devices, are associated with high emissions of particulate matter and other major emission constituents (IEA, 2008). For example, the particulate matter level per megajoule generated from traditional wood stoves can be 1 000 times higher than that from large-scale fluidised bed boilers (van Loo and Koppejan, 2002). Thus, using small-scale biomass combustion applications would not generally be advisable in urban areas without emission control measures.

Medium- to larger-scale combustion facilities generally use advanced combustion technologies with higher combustion efficiencies, appropriate operational procedures and effective flue gas cleaning measures, such as an electrostatic precipitator, baghouse or acid gas scrubber. Even so, emission levels need to be monitored periodically, noting affects from variations in feedstock composition, among other factors (Nussbaumer, 2010; Mikus *et al.*, 2016). As a by-product of flue gas cleaning, the fly ash emitted through the stack contains fine particle matter, toxic heavy metals and persistent organic pollutants such as dioxin, which remains an unresolved problem. In Europe alone, waste-to-energy plants emit more than 2 million metric tonnes of fly ash a year, or around 1% of the region's total annual waste production. Some progress has been made on this front: for example, NORSEP is testing a process to convert toxic fly ash into non-toxic residue and raw materials for other industries (EEA, 2016; Crouch, 2019).

19 Incomplete combustion in small-scale applications is a major cause of higher particulate matter emissions.

In comparison with fly ash, a greater amount of incinerator bottom ash is generated from the process. Normally, 18–25% of the mixed municipal solid waste ends up as bottom ash, a varied portion of which (including ferrous and non-ferrous items) can be technically recycled depending on the composition of the waste and on the legislation in any given country (ISWA, 2015). The remaining slag is usually used for the making of construction materials, subject to regulation and economics.

Among the variety of direct combustion/incineration technologies, the ones most commonly used in urban waste-to-energy facilities are mass burning, modular incinerators and refuse-derived fuel systems. Their key technological characteristics are described below.

**Mass burning** applications have been widespread – particularly in Europe, the US and Japan – since 1876, when the world’s first incineration facility was built in Nottingham, UK (German Environment Agency, 2008). Thousands of mass-burning systems exist worldwide, with daily waste capacities ranging from less than 100 tonnes to more than a couple thousand tonnes (Mikus *et al.*, 2016).

The technology is typically used to incinerate unprocessed solid waste, the composition of which varies from one discharge to another. Maximising complete combustion would require excessive amounts of air to ensure sufficient mixing and turbulence in the combustor. To achieve higher combustion efficiency, improvements have been made in the design of incinerators. However, the overall system efficiency is determined not only by the thermal conversion performance, which can be as high as 60% in the case of the water-wall incinerator, but also by the electric efficiency, which is usually much lower. The average net system efficiency ranges between 18% and 27%, while highly efficient systems can run up to 32% (Mikus *et al.*, 2016; ISWA, 2013; US EPA, 2018).

The **modular incineration** process (also known as starved-air incineration) also combusts unprocessed wastes in two-stage chambers, but this occurs, in most cases, under starved-air conditions. However, some configurations can operate under excess air. Unlike mass burning incineration, modular incinerators tend to be smaller in size, with capacities of 10 to 200 tonnes per day. They can be moved from one location to another when the waste is in short supply, and then scaled up in capacity when the waste increases. Modular incinerators also have cost advantages thanks to their pre-fabricated manufacturing and the reduced time needed for installation, although their life spans are only one-third to one-half those of mass burning systems (Mikus *et al.*, 2016).

In contrast, a **refuse-derived fuel** combustion system is designed to burn processed combustible waste in dedicated<sup>20</sup> combustion configurations using suspension or semi-suspension fired boilers and fluidised-bed boilers, among others. Although waste pre-treatment helps to enhance the thermal efficiencies, it poses technical and logistical challenges mainly associated with the extent to which metal and glass are removed from the waste stream. The pre-treatment requirements differ depending on the application of the refuse-derived fuel, for example whether it is to be used as fuel for a CHP plant or to produce industrial process heat (Giugliano and Ranzi, 2016; Mikus *et al.*, 2016).

Overall, waste pre-treatment seems to be a good approach to improve the thermal property of feedstock/fuels, but it causes problems that in many cases are hard to resolve in a cost-effective way.

---

<sup>20</sup> In most cases, co-firing with other fuels such as coal in a conventional combustion chamber under-performs and causes mechanical problems such as slagging or damaging the furnace wall.

## ANAEROBIC DIGESTION TO PRODUCE URBAN BIOGAS

Anaerobic digestion is another well-established waste-to-energy technology that is commonly used in cities. In this process, biodegradable waste is converted into energy through a series of bacterial digestion processes under anaerobic conditions in a bio-digester. The primary energy product, biogas, is a gaseous energy carrier that typically comprises 55–75% methane, depending on the feedstock composition and the bio-digester design. The biogas can be used for electricity generation, as a heating or vehicle fuel, or for injection into natural gas pipelines after being upgraded to the quality of natural gas by removing impurities<sup>21</sup> (Mikus *et al.*, 2016).

In cities, anaerobic digestion technology has been commonly applied in municipal wastewater treatment plants, municipal solid waste treatment plants, and waste treatment facilities affiliated with food or livestock industries. Biogas is a by-product of the waste handling system that requires treating sewage sludge and the decomposable fraction of municipal solid wastes. Biogas can also be collected from appropriately managed landfill facilities and is usually used for power generation rather than other purposes, due mainly to the remote location of landfill sites.

Anaerobic digestion systems in industries such as food processing, livestock, slaughter and pharmaceutical production are a crucial part of efforts to ensure that the wastes discharged from facilities follow environmental regulations.

The production of biogas as a by-product can improve the economics of such facilities to those industries (Al Seadi *et al.*, 2008; Bachmann, 2015). Utilisation of the biogas produced from these facilities not only improves the system efficiency of resource management by producing energy from the wastes, but also mitigates climate change by converting the methane into CO<sub>2</sub><sup>22</sup>.

Many European countries, including Austria, Germany and the Netherlands, are frontrunners in this area. For example, in Meppel, the Netherlands, biogas generated from the wastewater treatment facility is used to fuel a CHP plant serving a district heating network of 3 400 homes (van Leeuwen *et al.*, 2015).

Large-scale urban biogas production from municipal wastewater treatment plants, municipal solid waste plants and food processing has dominated the global market, with more than 20 000 biogas facilities worldwide and around 1 000 projects added annually. On the other end of the spectrum, small- and micro-scale bio-digesters – often designed specifically for individual households – are being adopted increasingly as an emerging technology for treating urban organic wastes. For example, around 1 000 household-sized HomeBiogas bio-digester systems, which utilise up to 12 litres of kitchen waste, have been deployed in more than 90 countries (Lemonde, 2020).

---

21 It consists mainly of CO<sub>2</sub> and trace amounts of water vapour, oxygen, nitrogen and hydrogen sulphide.

---

22 Methane's greenhouse gas emission factor is as much as 25 times that of CO<sub>2</sub>.



### 3.3 Urban wind power

Although wind power has developed significantly over the past decade, it has barely penetrated the built environment. Barriers to urban wind energy applications include the size of the prevailing wind turbines and their inability to capture low wind speeds and turbulent flows; the poor understanding of the aerodynamics of wind in cities; and visual and noise disturbance, among others.

While there are some examples of urban wind turbines generating electricity, their performance still need to be improved substantially, and large-scale implementation is absent. The use of wind turbines in urban environments is mainly in the research and development (R&D) phase. The lack of experimental data is a big drawback in the development of urban wind turbines.

However, as new turbine designs are implemented and their performance evaluated, progress could be made towards commercially viable solutions (Dilimulati *et al.*, 2018). The research necessary for the optimisation of wind turbines is performed using computational fluid dynamics (CFD) simulations of the wind. With this technology, good estimations can be made regarding wind behaviour around buildings. Subsequently, the wind potential can be calculated, and optimisations made for hub heights and costs (Yang *et al.*, 2016). However, these simulations are time consuming and require powerful computers, as urban areas can get very complex. Research is ongoing to simplify the models. Moreover, many CFD studies focus on just one building or on simplified urban surroundings, which can lead to uncertainties of up to 45%. Only 14% of reports reviewed by Toja-Silva *et al.* (2018) dealt with real urban environments (Simoes and Estanqueiro, 2016; Toja-Silva *et al.*, 2018).

There are three main options for wind turbine applications in cities: stand-alone, retrofitted on existing buildings and architecturally integrated into the building. The last two are grouped under the term building-integrated wind turbines (Stathopoulos *et al.*, 2018). The turbines themselves can be divided into two overall types: horizontal-axis or vertical-axis. Horizontal-axis turbines have dominated in recent decades, whereas vertical-axis turbines have been developed only in the past five to eight years, and their market share remains comparatively smaller.

The average rated capacity of a vertical-axis wind turbine is around 7 kW, while for horizontal-axis turbines it is much smaller (Pitteloud and Gsanger, 2017; Stathopoulos *et al.*, 2018). The latest research indicates that vertical-axis turbines are very promising for urban applications, as they can produce power from the turbulent and multidirectional winds of cities (Dilimulati *et al.*, 2018).

Worldwide (not just for city applications), the installed capacity of small wind turbines totalled around 948 MW in 2015. The market leaders in production and installation are China, the US and the UK (Pitteloud and Gsanger, 2017). However, urban applications are limited, due in part to social acceptance. Nevertheless, the many benefits of urban wind turbines include the ability to generate electricity at the same location as the consumption (resulting in no transmission or distribution losses), reduced dependency on a grid, reduction of greenhouse gases and support for sustainable development. Small successes have occurred in recent decades, indicating movement in a positive direction (Kumar *et al.*, 2018).

In 2015, Grieser *et al.* found that today's small wind turbines may only be profitable in specific and ideal situations. Their economic viability depends, among others, on the average wind speed, hub height and building density, as these are the main characteristics influencing the output power of turbines. For private households, investments in small wind turbines are only profitable with average wind speeds of 4 to 4.5 metres per second. Furthermore, building density negatively affects the profitability of the turbines. Additionally, Grieser *et al.* found that the inclusion of a battery system increased the net present value of a small wind turbine investment. Also, feed-in tariffs make investments for private households more attractive (Grieser *et al.*, 2015).

Horizontal-axis wind turbines are much less effective within cities as compared to open areas. The efficiency of the turbines decreases rapidly with the increasing turbulence of the wind. For conventional turbines, production can be optimised using diffusers or upstanding edges (Stathopoulos *et al.*, 2018). Urban applications also face challenges related to noise production, visual disturbance and public safety (Kumar *et al.*, 2018).

Horizontal-axis turbines are based on the lift principle of the wind. Designs can become complex because of the many different components involved, including the tower, rotor, yaw and brake mechanisms, blades, hub, gearbox and more. The height of the tower is also an important consideration in turbine design. The higher the turbine, the better the efficiency and the higher the power output. However, noise also increases with increased wind power. The main advantages of horizontal-axis turbines are their high efficiency and capacity, and the ability to scale them up easily for large power production.

The disadvantages are, in addition to those mentioned above, the risk of wildlife strikes, radar interference, maintenance and land use (Óskarsdóttir, 2014).

Among existing wind turbine technologies, horizontal-axis turbines operate the best with a strictly horizontal air flow and a small-as-possible surface roughness. They can reach very high efficiencies under uni-directional wind and are the most efficient for large-scale wind energy harvesting in open fields (Dilimulati *et al.*, 2018; Óskarsdóttir, 2014).

Vertical-axis wind turbines are a promising technology for urban applications in part because they are independent of wind direction, and winds in urban environments are very turbulent and multidirectional. The vertical-axis design eliminates the need for a yaw mechanism, and the turbines offer simple design, low maintenance and simple manufacturing. In several types of vertical-axis turbines, straight blades can be used, which greatly reduces the manufacturing costs. Vertical-axis turbines are easy to use modularly as separate units or when integrated into electrical networks (Saeidi *et al.*, 2013).

Vertical-axis wind turbines show better results on rooftops than in open fields, despite any technical or economic difficulties. They also produce less noise and have more appealing designs. The main disadvantages are that the turbines tend to stop operating under gusty conditions, have a bad starting torque, are poorly self-starting and suffer dynamic instabilities. Moreover, the turbines are designed to operate at low heights, so they are limited to lower wind speed conditions (Óskarsdóttir, 2014). Currently, vertical-axis wind turbines are most common in remote, off-grid applications (Óskarsdóttir, 2014).

The most well-known vertical-axis technologies are the Savonius and Darrieus turbines (Figure 20). Instead of lift, the turbines are designed with the drag principle of the wind. The Savonius turbine appears to be well suited for urban applications, as it has a simple microturbine design and works with relatively low start-up wind speeds. The Darrieus turbine is well suited for rooftop installations as it has low noise and vision disturbance (Dilimulati *et al.*, 2018; Óskarsdóttir, 2014).

At first glance, the characteristics described above make vertical-axis turbines more suitable than horizontal-axis turbines for applications in cities. However, horizontal-axis turbines are more efficient, even in cities, which has resulted in their more prevalent use.

Moreover, the cut in speed of horizontal-axis turbines is lower on average than for vertical-axis turbines, which is more favourable in an urban environment, and the starting torques are low (Stathopoulos *et al.*, 2018; Tummala *et al.*, 2016; Toja-Silva *et al.*, 2013).

The operational difficulties of vertical-axis turbines could be overcome using turbine controls. When the wind behaviour in cities is fully understood, these control mechanisms could be designed for rapid changes in wind speeds and torque (Dilimulati *et al.*, 2018). As the development and technologies of vertical-axis turbines continue to advance, their acceptance and costs will likely improve (Kumar *et al.*, 2018).

Figure 20: **Savonius rotor (left) and Darrieus rotor (right)**

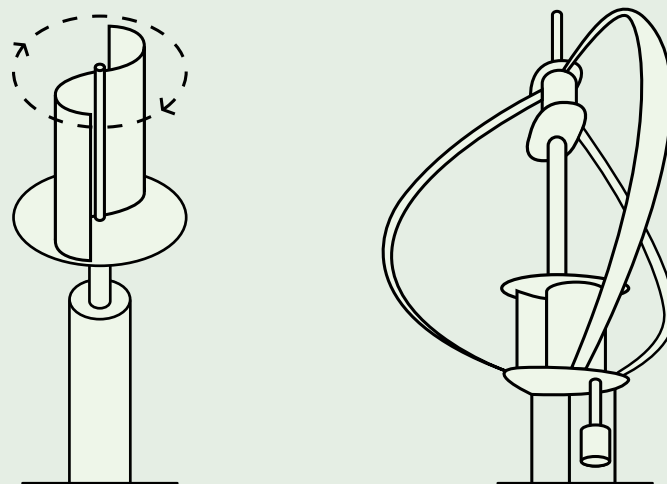

Source: [www.reuk.co.uk/wordpress/wind/savonius-wind-turbines/](http://www.reuk.co.uk/wordpress/wind/savonius-wind-turbines/) (left) and [www.reuk.co.uk/wordpress/wind/darrieus-wind-turbines/](http://www.reuk.co.uk/wordpress/wind/darrieus-wind-turbines/) (right)

### 3.4 Direct use of geothermal energy

Geothermal energy can be used directly to meet the demand for thermal services, mainly space heating and cooling as well as hot water in cities. This can be done by extracting energy stored in the rock or soil beneath the ground (at depths ranging from around 10 metres to hundreds of metres or deeper<sup>23</sup>), depending on the supply temperature and the quality of geothermal resources. Industry experts generally agree that lower-temperature geothermal energy (around 10 °C to 150 °C) is more suitable for direct thermal use than for power generation, which would require a much higher temperature to achieve the desired efficiency and economics; low-temperature geothermal resources exist in most countries (Lund, 2016; ESMAP, 2012; Moya *et al.*, 2018).

Low- to mid-temperature geothermal is also ideal as a heat source for district heating and can in many cases use existing district heating systems by simply replacing the fossil fuel heat source with a geothermal heat source. Geothermal district heating has proven to be a renewable, baseload and profitable alternative to fossil-based heating of cities.

With the need to decarbonise the heating sector, and recognising the potential and advantages of direct use of geothermal energy, applications in cities have been growing. The global installed capacity of direct use of geothermal energy has more than doubled since 2010, to reach 107 727 megawatts-thermal (MW<sub>th</sub>) deployed across 88 countries in 2019. This increase is driven largely by the ramp-up of geothermal (ground-source) heat pumps, which account for 71.6% of the total installed capacity, followed by space heating applications at 12% (Lund and Toth, 2020). The upward trend is expected to continue, as the Global Geothermal Alliance aspires to achieve more than two-fold growth in geothermal heating by 2030 (Box 4).

<sup>23</sup> This is no clear definition of the threshold between shallow and deep geothermal. Generally, anything between 15 and 400 metres depth is deemed a shallow geothermal resource. See <https://geothermalcommunities.eu/assets/elearning/6.22.Shallow%20Geothermal%20Systems.pdf>.

#### Box 4: Global Geothermal Alliance

Launched in December 2015 at the 21st Conference of the Parties to the United Nations Framework Convention on Climate Change (UNFCCC's COP21), the Global Geothermal Alliance offers an inclusive and neutral multi-stakeholder platform for enhanced dialogue, co-operation and co-ordinated action among public, private, intergovernmental and non-governmental actors that share a common vision of accelerating the deployment of geothermal energy for power generation and direct use.

The Alliance has an aspirational goal to achieve a five-fold growth in the installed capacity for geothermal power generation and more than two-fold growth in geothermal heating by 2030.

More specifically, the Alliance aims to:

- foster an enabling environment to attract investments in geothermal energy;
- provide customised support to regions and countries with geothermal market potential;
- facilitate the exchange of insights and experience among key stakeholders along the geothermal value chain;
- identify and promote models for sharing and mitigating risks to attract private investment and integrate geothermal facilities into energy markets; and
- promote the visibility of geothermal energy in the global energy and climate debates.

At present, the Alliance gathers over 70 Member countries and Partner institutions from the geothermal industry, development partners, international finance institutions and academia. For more information visit [www.globalgeothermalalliance.org](http://www.globalgeothermalalliance.org).

In terms of applications, direct use of geothermal energy can be integrated into district heating and/or cooling systems in cities or installed as a stand-alone system for an individual building or building block in cases where the heat demand is inadequate to justify investing in new thermal networks. Geothermal district heating relies on wells that average around 2 kilometres deep but that require very little surface area, and the wells and the accompanying heat centrals can easily be woven into the cityscape, virtually invisibly. In Europe alone, at least 25% of the population lives above geothermal resources that are ideal for geothermal district heating, replacing the fossil district heating of today<sup>24</sup>.

In general, the installation of a geothermal energy system for direct use is much easier (and thus less costly) in a new building, block or city quarter, rather than fitting it in with existing structures. However, this does not mean that the systems cannot be deployed in existing architectures or neighbourhoods. For example, Switzerland, which has 5.32 MW<sub>th</sub> of geothermal capacity per 100 square kilometre and the world's highest density of borehole heat exchangers, ranked first in the direct use of geothermal energy per land area in 2019. Since 2011, more than 30% of all drillings in the country were done for existing building stocks, leading to an estimated 700–800 kilometres of new borehole heat exchangers (Scanner, 2017; Lund and Toth, 2020).

Geothermal (ground-source) heat pump systems – the most commonly adopted systems – consist of the ground system and an attached heat pump, with the other end of the heat pump being connected to the heat distribution network inside buildings to provide thermal services.

For the ground system, the most common types are open-loop and closed-loop systems, and the latter can be broken down into two categories, horizontal and vertical. Their key characteristics are described in Table 5.

In most cases, geothermal borehole drilling is needed; however, horizontal ground-source heat pump systems typically require only soil removal or shallow trenches of less than five metres deep. Both are very costly and account for a large share of the total project cost, although the horizontal configuration is comparatively cheaper but requires greater land area for trenching, which can be challenging in cities.

Given that geothermal energy can be used for both heating and cooling during different seasons or times, a hybrid system is able to use the shallow ground as thermal energy storage, essentially compensating for the natural replenishment of the geothermal energy. Borehole thermal energy storage systems (BTES) and aquifer thermal energy storage systems (ATES) are two commonly adopted technologies (Bayer *et al.*, 2019).

Lastly, it should be noted that the waste heat discharged from geothermal power plants is often used to meet a range of heating services in cascading fashion, from district heating to fish farming, thus enhancing the system's energy efficiency and economic performance when high-enthalpy geothermal resources can be exploited in or near a city (Moya *et al.*, 2018). Globally, the installed geothermal power generation capacity totalled 14 GW in 2019, much of which is configured as CHP (IRENA, 2020c).

---

24 See [www.geodh.eu](http://www.geodh.eu) under "Potential".

Table 5: Key characteristics of open-loop and closed-loop geothermal heat pump systems

Ground system		Heat source	Heat transfer fluid	Scale	Depth
Open-loop (constrained by the availability of suitable aquifer)		Aquifer (ground water)	Ground water as medium of heat exchange with the earth	Large (e.g., 10 MW <sub>th</sub> in Louisville, Kentucky, US)	In most cases two wells/doublets, less than 50 metres deep
Closed-loop	Horizontal	Solar radiation absorbed/stored in the top earth layer	Refrigerant circulated in the heat pump's evaporators	Small-scale	Typically less than 5 metres deep
	Vertical	Solar radiation in the upper part, with geothermal thermal in the deeper part	Synthetic heat carrier fluid	Small and large depending on the number of borehole heat exchangers (BHEs); highest per plant density in Europe: 154 BHEs each 70 metres deep; in the world: 400 BHEs each 130 metres deep	15–20 metres to several hundred metres deep using BHEs, generally around 100 metres
Others:	Standing column well	Same as the vertical closed-loop	Same as the vertical closed-loop	Large	Several hundred metres
	New concept	Water from mines and tunnels			

Based on Scanner, 2005

### 3.5 Smart grid development through innovation

To implement the above renewable energy options in cities, the urban energy infrastructure, particularly power distribution grids, must be flexible to accommodate high shares of variable renewables in cities (notably, solar PV, but also potentially wind power near to cities). At the same time, the energy infrastructure must be “smart” to integrate applications in other sectors such as transport and heating and cooling.

Advanced digital technologies, which have increasingly been adopted in power systems, demonstrate strong potential to maximise the benefits and integration of renewable energy technologies by automating the monitoring and operation of assets (Hossain *et al.*, 2016).

Digital technologies can be used to balance the variability of certain renewables – particularly variable renewables with loads, such as small-scale solar PV and micro wind turbines – through data-driven forecasting technologies, energy storage systems, EVs and other sector-coupled technologies, thereby enabling increased integration of VRE in local energy networks (Hossain *et al.*, 2016).

Nevertheless, the continued development of smart grids and their optimised operation and management requires innovations in enabling technologies and distribution power system operation, such as behind-the-meter batteries, EV smart charging and advanced weather forecasting tools; at the same time, new business models and market design and regulation such as net billing schemes and time-of-use tariffs are equally important (IRENA, 2019a). This is increasingly critical as urban energy systems become more complex, renewable-based and decentralised over time.

In return, smart grids present new opportunities not only for higher shares of variable renewables, but also for system efficiency improvement. An estimated 20–30% of energy consumption in buildings could be saved through optimised operation and management, without major hardware changes within buildings. Similarly, a smart grid with sound demand response strategies – underpinned by a variety of technologies associated with incentives and time-of-use pricing schemes – could better integrate higher shares of VRE by shifting energy consumption (or production) to periods of low (or high) demand and efficiently utilising storage systems (if installed), while reducing electricity consumption. An effective demand response scheme could reduce peak electricity demand by an estimated 10–15% in most cases. (Reynolds *et al.*, 2017).

However, to implement concrete innovative solutions, smart grids in the distribution networks would need to be complemented with changes to existing market design and regulation, as well as smart grid protocols for interoperability between assets and systems (DNV GL, 2019a).

Thanks to digitisation, new business models are being enabled that create opportunities for both consumers and system operators alike. For example, the emergence of new actors such as aggregators that bundle distributed energy resources into a single virtual power plant can be an integral part of the solution to facilitate the scale-up of VRE in cities (IRENA, 2019c). Another innovative solution that is highly relevant for cities, especially in unbundled power sectors, is the creation of local flexibility markets in which the distribution system operator can acquire flexibility from an online marketplace that brings together all resources available at the distribution level. Ongoing initiatives are being piloted in the UK and Germany by various stakeholders (IRENA, 2019g).

With increasingly digitalised end-use sectors, the forward-looking technological breakthroughs in artificial intelligence, when integrated into smart grid management systems, would offer a promising opportunity to maximise the efficiency of future energy systems and the market, with high shares of VRE sources coupled with energy storage systems and other sector-coupling technologies (DNV GL, 2019b).

Smart charging for EVs is a good example of this. With the growing number of EVs, uncontrolled charging poses a mounting challenge to the operation of distribution grids because it can create a rapid surge in power demand and lead to high grid congestion. This raises questions about how peak charging loads should be handled, and about what policy and regulatory frameworks would need to be put in place to ensure effective integration of the transport and power sectors in an urban context.

IRENA's *Innovation outlook: Smart charging for electric vehicles* shows that smart charging supported by digital technologies can facilitate the integration of high shares of variable renewable generation. Smart charging takes advantage of the battery storage capacity that EVs must improve grid flexibility, while at the same time reducing the peak load compared to what otherwise would be, as well as reducing the cost for charging (IRENA, 2019b).

Some of the digital technologies now available are relatively new and need to be better integrated into urban energy systems. Smart grids continue to struggle with non-standardised and sparsely distributed digitalisation technologies, as well as underdeveloped regulations. A report by Eurelectric identifies regulatory gaps inhibiting smart grid investments in the EU (Rodrigues da Costa *et al.*, 2011), including sub-optimal rates of return and regulatory instability.

Regulators are also employing limited cost efficiency evaluation schemes, which are seen to penalise for spending on R&D or smart grid pilot projects and instead encouraging business-as-usual expenditures (Rodrigues da Costa *et al.*, 2011).

In addition, the perceived lack of clarity on the roles and responsibilities of individual market players has slowed the roll-out of smart meters, a key device to provide actors with detailed information on the electricity consumption patterns of end users and hence an essential component to a smart grid and new business models (Rodrigues da Costa *et al.*, 2011). Reynolds *et al.*, 2017). A key evolution observed in the Northern European countries is the creation of so-called data hubs for electricity metering data, made available on a level playing field to various actors in the power sector, including consumers (IRENA, 2019g).

Options exist to tackle these challenges. The first step is to acknowledge the need to combine technical requirements for hardware, software and communication protocols, enabling policies and supportive regulatory requirements, as well as in terms of clearly defined roles and responsibilities among established and emerging actors in municipal power systems. For example, to facilitate the development and implementation of smart grids, unified control and management strategies should be implemented and perfected through an iterative learning process between theory and application, including system operators, consumers, technology providers and power generators, among others.



### 3.6 District thermal energy networks

District heating has long been applied worldwide. It is suitable for urban areas that have high linear heat densities, where the investment in thermal grid infrastructure can be financially and economically justified, and where higher energy efficiencies can be achieved. Until recently, 90% of district heating demand was met with fossil fuels (through CHP) and through heat supply plants that generally produce higher-temperature hot water (Werner, 2017).

In recent years, renewable energy has assumed a greater role in district heating. This is thanks largely to a new generation of thermal grid technology that allows for the use of lower-temperature heat sources (often below 70 °C), such as renewables (including solar thermal and geothermal in conjunction with thermal storage systems and electric heat pumps). When a low-temperature supply is required for the district heating network, heat pumps can be used to improve the system efficiency and the resulting economic performance.

Increasingly, surplus renewable electricity-to-heat using conventional technologies such as electric boilers and heat pumps offers another option for heat generation. This can be integrated into the CHP plants connected to district heating systems, resulting in a 30% reduction in fuel consumption on average. It can also be operated at a stand-alone heat supply facility when thermal energy storage systems are equipped to ensure consistent heat supply. In the current generations of district heating technologies, waste-to-energy and waste heat from CHP or industrial processes could play a bigger role as part of measures to decarbonise the urban energy mix.

District cooling is less commonly used than district heating due to a lack of technological maturity and the unfavourable economies of scale. But the situation is changing as cooling demand is expected to increase rapidly in the coming decades. If the demand for cooling follows the business-as-usual approach of using electric air conditioning, the resulting surge in peak demand will pose a huge challenge to the electric power system. Therefore, alternative solutions must be sought. In this context, renewable-driven district cooling offers enormous potential.

Free cooling sources such as rivers, lakes and ambient air can be exploited as the source of cooling energy. In addition, solar thermal-driven absorption chillers can produce cooling energy to supply cold water through cooling distribution networks to meet the demand for space cooling or cooling for industrial processes in cities, particularly in large public and service buildings such as office buildings and hotels.

Distribution of cold water is performed using a small design temperature difference between the cold supply temperature and the warmer return temperature. Hence, district cooling pipes are much wider than district heating pipes at the same capacity demand. Cold losses are very small in Europe, where the annual average ground temperatures are almost equal to the distribution temperatures. Higher ground temperatures in the Middle East call for greater insulation of pipes.

Cold deliveries are managed by sub-stations in each connected building, with or without heat exchangers. Since the temperature difference between the supply and return pipes is very small, heat exchangers with long thermal lengths are used in the sub-stations in order to not reduce the transfer capacity in the cold distribution networks. Shorter thermal lengths result in lower return temperatures and lower temperature difference in the distribution network.

A forthcoming IRENA knowledge product, *Technical guidelines for the development of bankable renewable energy heating and cooling projects*, will provide greater details about the fundamentals of heating and cooling networks and how to design them along with heating and cooling production units/plants (Box 5). A second forthcoming report, *Thermal energy storage in district heating and cooling*, will offer a comprehensive review on the technologies, exemplary cases and outlook (Box 6).

#### Box 5: **Technical guidelines for the development of bankable renewable energy heating and cooling projects**

The forthcoming *Technical guidelines for the development of bankable renewable energy heating and cooling projects* (IRENA, forthcoming b) will support the development of renewable energy heating and cooling solutions for cities-related applications including residential, industrial and commercial end uses.

The guidelines focus on bankable project alternatives for each configuration and load requirement with practical details such as energy audits, process integration, technology selection, technical design, cost estimation and financial modelling. The report covers the key steps in the project development cycle from project identification to decommissioning.

**Box 6: Thermal energy storage in district heating and cooling**

Thermal energy storage (TES) can significantly accelerate the decarbonisation of thermal energy systems, particularly in cities where the population density is high enough to adopt district heating and cooling systems. With TES that enables the decoupling of heat/cold generation from consumption, such a role could be amplified. In addition, TES can enhance the system efficiency in district heating and cooling across a range of time scales – from short (hourly) to long (seasonal) – to provide flexibility, to better link the supply of heat/cold to actual demand.

TES also helps to take advantage of renewably generated off-peak electricity. It can also reduce the capital costs for new heating or cooling capacities that would otherwise need to be installed.

A forthcoming IRENA outlook on TES (IRENA, forthcoming c) considers the different technologies and user cases for heating and cooling systems and projects the outlooks for different TES technologies in the short, medium and long terms, based on an analysis of current and future research and development directions.

In contrast to the conventional approach of providing heating and cooling services through two separate thermal pipeline networks, an innovative design being incorporated in the next generation of thermal grids, such as ectogrid™, uses a single thermal network connecting with different end-users to move around the wasted thermal energy (e.g., the discharged waste heat from cooling systems, such as those used in data centres, hospitals and office buildings). Meanwhile, heat pumps can be used to tap into low-temperature thermal energy as a way to increase the temperatures required, while cooling machines or reverse-cycle heat pumps can be used to reduce the temperatures to a desired level.

The primary advantage of such an approach is the greater overall energy efficiency that results from reusing the wasted thermal energy discharged from different end users in the system before adding additional energy when needed.

In addition, thanks to the low-temperature thermal energy in the pipeline, this approach reduces if not eliminates the distribution losses, and it enables the applicability of renewable-based thermal energy as a supplementary source.

Such a thermal grid can operate as a stand-alone with the connection to more than two end-use facilities, with the capability to expand as demands grow, thanks to its modularised configuration.

Although such a system can also be integrated into existing thermal networks to bring greater energy efficiency and system flexibility to existing urban areas, its economic justification depends highly on energy fuel prices, especially for natural gas. For new areas and for countries that have high natural gas prices, the economic advantage is apparent when compared with conventional thermal energy systems.

# 4.

## MODELLING TOOLS FOR URBAN ENERGY SYSTEM PLANNING

## 4. Modelling tools for urban energy system planning

Urban energy systems are unique in that they involve not only the physical energy infrastructure, but also important social elements such as public acceptance, consumer preferences and behaviours, willingness-to-pay and affordability. Establishing effective local power generation and meeting targets for renewables depend on employing a sound process and tools for urban energy system planning.

The planning process allows the formulation of a well-informed, sustainable urban energy system plan. Many institutions have developed effective frameworks and practical tools to guide local authorities throughout the planning process (Saheb *et al.*, 2014; Hemis, 2017; UN-Habitat and ICLEI, 2009).

In addition, energy planning must be integrated into urban planning as early as possible, as urban forms, functionalities and zoning have significant impacts on energy demand and increasingly also on energy production, particularly with the proliferation of prosumers (Zanon and Verones, 2013; Rickwood *et al.*, 2008; Nuorkivi and Ahonen, 2013). Further, enhancing urban resilience in response to climate change needs to factor in long-term planning, as urban energy infrastructure typically has a life span of up to 50 years or more (Reckien *et al.*, 2018; Mirakyan and De Guio, 2015).

A sound process also requires the right planning tools for urban energy system development. Although a wide range of modelling tools are available to support urban energy system planning, the tools vary in their ability to address issues associated with different spatial and temporal scales, as well as in their technology representations, underlying methodologies and analytical scopes. Growing shares of local renewables in urban energy systems also requires an increasing understanding of the tools available for urban energy system planning. These can help to determine the feasibility of renewable energy solutions in early planning stages, the design of renewable energy systems (e.g., sizing and operation) at later planning phases, and strategic planning with a special focus on renewable energy.

Local authorities and energy experts must therefore gain a better understanding of the most suitable modelling tools for urban energy system planning, identified and evaluated against their capabilities to consider, identify, integrate and scale up renewable energy technologies in cities. In addition to exploring the available tools, this chapter discusses possible data challenges when applying them, as well as pathways to address these challenges. Lastly, modelling challenges are discussed in the context of developing countries, given that 90% of urban population growth in the next three decades is expected to come from these countries, chiefly from Asia and Africa (UN DESA, 2018).

#### 4.1 Data challenges: Required data, temporal and spatial granularity, and accessibility

All energy system models require at least some data, and many require large input datasets. The output quality of any model is, to a great extent, dictated by its input data. Reference databases can address data gaps to some degree, but significant challenges remain. In urban energy system planning, more granular data are required compared to large-scale models, which are often more challenging to collect or obtain. Data gaps exist due to limited data availability and accessibility for various reasons, ranging from non-existence to non-disclosure.

The sections that follow describe key datasets needed in urban energy system modelling, along with commonly encountered challenges in urban and renewable energy system planning.

##### DEMAND DATA

Hourly-scale urban energy models require hourly demand profiles covering at least a one-year period. Demand data include hourly profiles by energy end use (including electricity, space heating and cooling, domestic hot water and process heat) and by zoning sector (e.g., residential, commercial, and industrial and transport). Within zoning sectors, demand data are also required on different energy consumption patterns at varying spatial scales (e.g., for different residential building types, such as single- and multi-family homes, and for different commercial business types, industries and transport modes). Long-term models require demand projections for future years. These projections must also consider local climate change impacts (e.g., increased cooling demand and decreased heating demand due to rising temperatures).

Demand elasticity and flexibility data are needed in demand-side management models as well. Demand elasticity in the context of energy systems refers to how sensitive energy demand is to changes in economic variables, such as the energy price. Modellers require demand elasticity factors for energy commodities (such as heat, electricity, natural gas and other fuels), by application (e.g., electricity for different appliances, EV charging and cooling) and by zoning sector (e.g., the residential, commercial, industrial and transport sectors exhibit different demand elasticities for electricity).

Demand flexibility refers to a user's ability to forgo, shift or substitute certain loads. For example, users may have the flexibility to forgo or shift heat demand (e.g., by turning on a heating device at a different time), depending on the thermal capacity and insulation characteristics of buildings or if thermal storage is available. Users may also forgo demand by adjusting comfort levels in buildings. In the case of substitution, a user may switch to alternative energy sources and technologies in response to long-term price signals (such as switching from fossil fuel-based boilers to heat pumps, switching to higher-efficiency appliances or switching to alternative fuel vehicles).

Efficiency measures also affect energy demand, including building renovation potentials for various levels of retrofitting (e.g., window replacement, improved insulation and full building retrofits). These data are required per building type, alongside cost data and feasible retrofit rates over time.

Long-term models considering efficiency measures also require data on future trends in end-use technology and converter efficiency gains and costs (e.g., for lighting, cooking, refrigeration, dishwashers, other appliances and end-use technologies in the commercial/service and industrial sectors).

## SUPPLY DATA

Hourly supply profiles provide information on (potential) energy generation and fuel supply (e.g., grid electricity, natural gas, wood, biofuels, transport fuels and other fuels) by zoning sector and end-use application. The existing electricity supply mix (i.e., shares from different non-renewable and renewable energy power plants) is also part of supply data as a basis for calculating the future mix, with different temporal and spatial scale requirements depending on the energy resource type.

For solar and wind energy, at least hourly generation data are needed throughout a year, whereas hydropower may be estimated seasonally, and wood and waste potentials may suffice on an annual scale. Spatial information is particularly relevant for solar, wind and hydrological resources.

Details on supply technologies are also required in urban energy models. This includes information on installed capacities, efficiencies and availability factors for existing decentralised renewable energy technologies, heat and electricity generation plants, and storage solutions, as well as the capacities that could potentially be installed. These data also can include peak supply technologies and reserve capacities.

For building-level solar energy applications, data such as rooftop and/or façade installation potentials; shading by surrounding buildings, trees and other infrastructure; and building zoning restrictions (e.g., heritage-protected buildings) are also required to estimate potential solar energy supply.

Data on the installation potential are required to estimate the capacity of larger distributed renewable energy installations as well. These include ground-mounted solar PV and thermal collectors, biomass-based or waste-to-energy CHP plants, large-scale ground-source heat pumps, district-level energy storage systems (e.g., for seasonal thermal energy storage and large-scale battery storage), wind turbines and small hydropower plants. The latter are often sited on the outskirts of a city/district or are developed in conjunction with industrial zone development.

## URBAN INFRASTRUCTURE DATA

Urban infrastructure data include network layouts of electricity distribution grids (line capacities, transformers, sub-stations and their configurations); district heating, cooling and gas networks (pipeline capacities and temperatures); transport networks (roads, railway lines, metro lines, bus lines, fuelling stations and parking lots); and network losses and lifetime data. These data are crucial to determine the amount of VRE that can be accommodated by existing urban infrastructure and to estimate the investment need for infrastructure enhancement.

Buildings, as part of urban infrastructure, shape the urban form. Databases are needed on building function and structure (e.g., number of floors, number of occupants, construction date, past renovations, heated area, rooftop area, façade area, etc.), existing energy converters (e.g., heating technologies and onsite power generation) and access to energy networks (e.g., natural gas, district heating, electricity distribution and transport network access).

Urban transport models require information about the transport fleet, such as the number and types of vehicles (fleet composition), age, passenger- and vehicle-kilometres, driving profiles and fuel consumption rates.

Urban infrastructure data include spatial (*i.e.*, geographic information system, or GIS) information as well. However, detailed spatial and network infrastructure databases are generally large, and many cities face big challenges with data collection and processing for urban energy systems planning (Zhou *et al.*, 2016). Additionally, many modelling tools lack spatial and network representation, which are normally handled in later planning stages using specialised tools (*e.g.*, power systems models and GIS-based building models).

### ENERGY TECHNOLOGY DATA

Energy generation technologies using both renewable and non-renewable fuels, as well as storage technology data, form a core part of urban energy models. Data requirements include local costs (*e.g.*, investment, operation and maintenance, and disposal costs) and performance factors (*e.g.*, efficiencies, availability factors and losses) for different system sizes (*e.g.*, from single households in kW to city-scale small power plants in MW). Estimated future trends in costs and performance factors are also needed.

In long-term models, particularly for renewable energy technologies and storage solutions, where costs have fallen more rapidly than projected in recent years, according to IRENA's studies.

### MICROCLIMATE AND WEATHER DATA

Urban microclimates refer to areas where local climate conditions differ from the surrounding region. They can impact local temperatures, precipitation, air pressure, cloud formation and wind patterns. Long-term urban energy system planning models also need to reflect how global climate projections will impact these microclimate aspects in the future.

Urban heat island effects are part of urban microclimates. They refer to increased temperatures in cities compared to surrounding areas due to land surface modification and waste heat energy generation. Sub-surface urban heat island effects need to be considered when geothermal energy is included in the technology portfolio.

Microclimate and weather data are needed to support smart energy management in cities. Solar insolation, cloud coverage, wind speed and temperature data can be used for renewable power generation forecasting, demand forecasting and system fault identification in models (Zhou *et al.*, 2016).



## TEMPORAL AND SPATIAL GRANULARITY OF DATA

### *Temporal granularity*

For urban energy system planning with a special focus on VRE, higher temporal resolutions are usually required. Depending on the application, this varies from hourly scales for detailed power system planning to seasonal scales for hydropower technologies in urban energy system planning. Hourly data are often employed in planning tools, although many of these tools offer the ability to modify the time-step duration or representation.

However, data are often available/collected at a lower temporal resolution than required for modelling. Energy-related organisations (e.g., energy agencies, government offices, national statistical institutes and energy system operators and distributors) generally provide energy supply statistics at an annual level, but not at higher temporal resolutions. Thus, disaggregation methods to scale down data (e.g., estimating or simulating hourly demand based on annual energy demand data and other statistics) may be employed.

With the increased roll-out of smart meters, and of sensors at the power-plant level, demand and supply data gaps can hopefully be bridged. Smart meters collect data on an hourly level down to a multi-second level (Stegner *et al.*, 2016; FERC, 2008). These data are suitable for urban energy modelling given their high temporal and spatial resolution.

However, not all data are required at high granularity. Annual-level or absolute data are suitable for urban energy system planning in several cases, such as total renewable capacity installation potentials, some renewable energy resource potentials (e.g., annual waste, wood and manure potentials), building renovation potentials and urban infrastructure data.

### *Spatial granularity*

Data with a high spatial resolution are needed for site-specific renewable energy planning in urban energy systems. As in the temporal case, highly granular data on both the supply and demand side in urban energy systems are often lacking. Disaggregation and aggregation methods may be applied to estimate data gaps in these cases, or coarser modelling resolutions than desired can be employed.

When urban energy models employ high spatial and temporal resolutions (e.g., representing individual buildings with hourly demand profiles), modellers must ensure that the building demand profiles collectively represent realistic diversity conditions. In technical terms, the simultaneity (or diversity) factor of the system should be reasonably greater than 1<sup>25</sup>. This ensures that the urban energy system will not be oversized to meet overestimated peak demands.

---

<sup>25</sup> The simultaneity or diversity factor is defined as the ratio of the sum of the individual maximum demands of a group of consumers within a specified period, to the simultaneous maximum demand (i.e., system-wide maximum) of these consumers within the same period. The value is  $\geq 1$ .

Specialised planning tools exist that can provide more spatial depth, depending on their scope. For instance, tools focused on urban planning rather than energy planning (e.g., UMI), and specialised system analysis tools (e.g., power flow network models) require significant spatial information (e.g., 3-D models of all components in the urban environment and detailed distribution network maps). However, such tools usually have a limited view/analysis of the holistic energy system.

#### DATA AVAILABILITY AND ACCESSIBILITY

In most countries, energy statistics at the city level have not yet been established systematically, simply because the central government has not required it in many countries. Meanwhile, data collection on renewable energy resource potentials and technology installation potentials at the building, district or city levels has rarely been performed. Demand elasticity data are rare as well, even in European cities (Silva *et al.*, 2018). Data on building renovation potential are also scarce.

Worldwide, most cities have limited information and communications technology (ICT), such as smart meters, to collect data, although investments in smart meters are increasing rapidly, particularly across Europe and Asia.

Appropriate ICT infrastructure is especially relevant in the case of decentralised renewable energy integration, where new and previously unmonitored datasets are required (e.g., regarding the collection of generation, consumption and exchange data from prosumers in local energy networks).

Infrastructure databases, such as consolidated building inventory data, are not necessarily available for cities. This is expected to be a more pronounced issue in developing countries, where a significant share of the urban population may live in slums – for example, almost 30% of city dwellers in the Asia-Pacific region currently live in slum areas (Heyzer, 2014).

Even when data are collected, data formats vary greatly owing to a lack of centralised regulatory standards and metrics on how such data should be collected, handled and reported. Data can also be privately owned across multiple sources, which limits accessibility due to concerns and regulatory restrictions regarding data privacy and misuse.

Privacy, ownership, metric standards and other data management issues must be addressed in parallel with the acceleration of deploying digital technologies to collect energy data that can be used for urban energy system planning.

## 4.2 Modelling tools

A wide range of models and tools are available for urban energy systems planning, spanning different spatial scales, temporal scales, technology representations, underlying methodologies and analytical scopes. A comprehensive study was undertaken to evaluate these models and tools, identify prevailing gaps and challenges in the field, and propose recommendations to improve the tools/methods and their uptake by urban energy planners.

Based on the thorough evaluation of tools relevant to local-scale renewable energy applications (*i.e.*, from project to city-wide scales), seven stand out as being widely suitable and commonly used: OSeMOSYS, Balmorel, EnergyPLAN, HOMER, TIMES, MESSAGE, and LEAP. These tools – discussed further in the sections that follow – have been identified and evaluated based on their capabilities to consider, identify, integrate and scale up renewable energy technologies in cities.

### OSeMOSYS

**Basic description:** OSeMOSYS (Open Source Energy Modelling System) has been under open-source development since 2010. It is a least-cost, linear optimisation programme that provides long-term investment and operational decision support. Users can define slices (down to an hourly level) and modelling horizons. The programme can model all renewable energy technologies, conventional energy technologies and storage technologies (Groissböck, 2019).

**Considering:** OSeMOSYS provides a high degree of flexibility in modelling renewable energy and other energy technologies. Any technology can be defined as a single to multi-input/output process with conversion efficiencies and input/output shares. Availability factors can be specified per time slice (enabling the representation of maintenance planning and part-load operating conditions), and ramping rates can be modelled as well. Users have the flexibility to customise the length of time steps (time slices) for their application, down to an hourly scale, which is appropriate for VRE technologies (*e.g.*, harnessing solar and wind energy). However, time steps shorter than an hourly level are not possible.

All renewable energy resources can be represented, and renewable generation can be curtailed. The model is set up to easily specify renewable generation targets through constraints. All costs can be represented, and future costs can vary by year; however, a drawback is that it appears that variable costs cannot be specified by time slice (*e.g.*, sub-annually). This makes it difficult to implement time-of-use/peak electricity pricing. Another modelling drawback is that ambient or part-load conditions cannot impact renewable energy technology performance (*e.g.*, ambient temperature on PV performance). However, technology degradation/ageing can be modelled.

**Identifying:** OSeMOSYS uses a linear optimisation approach that minimises total system costs. It is a perfect foresight model that assumes perfect market conditions, and it has a single objective of cost minimisation, which can limit certain types of analyses (*e.g.*, multi-criteria decision analysis).

These are limitations of the underlying approach, common to many energy modelling tools. (All models, in general, are poor at modelling social behaviour and irrational decision making.) OSeMOSYS does not focus on stochastic and uncertainty analysis, although a stochastic extension has been developed, and sensitivity analyses can always be performed. Within its optimisation framework, the tool is useful for optimal long-term investment planning for renewable energy technologies; sizing of the technologies can assume either integer or real variable values.

Scenarios can be used to evaluate different policies and targets to encourage the uptake of renewable technologies (e.g., carbon taxes, emissions targets and renewable generation shares); however, not all policy mechanisms can be easily modelled (such as feed-in tariffs and variable electricity pricing).

**Integrating:** OSeMOSYS can be used to model an entire city's energy system, integrating all sectors and system interactions to identify where renewable energy technologies can be optimally integrated. City segments can also be modelled as individual regions that interact with one another.

All energy demands and supply (e.g., renewable) resources can be represented; however, demand is defined exogenously, and demand elasticity cannot be modelled. Network connections and energy imports/exports can be modelled, although OSeMOSYS is not a power flow model, and most operational details (e.g., line voltage) are not explicitly represented.

A range of storage technologies (important for VRE integration) can be modelled with sufficient technical detailing (e.g., depth-of-discharge and storage efficiency), but some parameters (e.g., standby losses) are not included.

**Scaling:** OSeMOSYS is a flexible framework that can be adapted to any scale, from a single building to a large city. It is appropriate for both greenfield and brownfield investment in renewable energy and operational planning (i.e., for both new and existing city segments) in both the short term (e.g., one year) and long term (e.g., 50 years). Users can also represent economies of scale for renewable energy technologies.

**Usability:** OSeMOSYS is a free, open-source tool with a high degree of transparency. However, as is the case with many open-source tools, this translates to a lack of technical support for users. A background in optimisation modelling and computer skills (e.g., GAMS and Python) is needed to use OSeMOSYS, although a basic graphical user interface has been developed to help bridge this gap. OSeMOSYS may require more training than other tools, and users must supply all modelling data.

**Overall:** OSeMOSYS is a powerful, free optimisation tool that can be used to model an entire city's energy system. Users can identify cost-optimal pathways for integrating renewable energy in the long term by considering a range of climate, technology and policy scenarios. The tool does not offer as much flexibility as the similarly structured TIMES model (see below); however, OSeMOSYS is relatively young and under continual development. Its largest drawback may be that it is not suitable for inexperienced modellers.

## BALMOREL

**Basic description:** Balmorel is a partial equilibrium model that supports both long- and short-term investment and operational decision making. It is implemented as a linear, least-cost optimisation problem. It was developed in 2001 and has been maintained as an open-source model ever since. Balmorel can model a wide range of renewable energy technologies and other technology options. It has mainly been applied to analyse and expand existing energy systems, such as the integration of heat pumps into the district heating system of Copenhagen or to analyse that city's CHP system. Most existing studies focus on renewable energy integration and the effectiveness of policy mechanisms to improve uptake of renewable energy technologies.

**Considering:** Balmorel can model almost all renewable energy technologies (except for tidal). It provides the flexibility to represent multiple-input/output technologies, and key technology parameters can be specified, including availability factors and all costs (including balancing costs). However, year-varying and time step-varying costs cannot be specified. Users have the flexibility to define time steps from divisions of one hour to five years. Renewable energy sources can be curtailed, but they do not degrade with age, and ambient and part-load conditions do not affect technology performance.

**Identifying:** Balmorel is another linear optimisation, partial equilibrium model that is limited by perfect foresight and market assumptions. The tool is useful for long-term urban energy scenario modelling to identify cost-optimal renewable energy pathways.

Most climate policy measures (e.g., carbon taxes, emission targets, renewable energy shares, self-sufficiency measures and fossil fuel consumption limits) can be evaluated to promote renewable technologies, but certain policy instruments (e.g., time-varying electricity pricing policies) cannot be represented. Balmorel is useful for both capacity and operational planning for renewable energy technologies, and the technologies can be sized as integer or real variables.

**Integrating:** Balmorel can be used to model an entire city's energy system, but there is significant sectoral aggregation outside of the residential and transport sectors. The tool focuses on electricity and district heating for renewable energy integration, but other demands can also be represented. Demand elasticity and response can be modelled as well. Balmorel can represent a range of storage devices, including short- and long-term storage for electricity, heat, hydrogen, and even carbon capture and storage. Network connections can be represented as simple transport processes (e.g., between segments of a multi-district city model), and energy trading (imports/exports) can also be accounted for.

**Scaling:** Balmorel enables multi-year investment and operational planning for renewable energy technologies through long-term scenarios (up to 50 years). It can be used to represent city segments on any scale, but is better suited to brownfield analysis. Economies of scale can also be represented in the modelling framework.

**Usability:** Balmorel is a free, open-source tool with high transparency. As such, technical support is limited. It does not have a well-developed graphical user interface, and users should be technically adept. Advanced users can build on the open-source code, and the recommended training period is typically one week.

**Overall:** Balmorel has been in development for almost two decades, making it one of the oldest free, open-source models evaluated. It does not allow for as much sectoral disaggregation as other tools and it does not model tidal technologies, but Balmorel is otherwise a very capable tool for cost-optimal renewable energy capacity and dispatch planning in cities.



## ENERGYPLAN

**Basic description:** EnergyPLAN is a bottom-up simulation tool designed to evaluate both greenfield and brownfield (*i.e.*, both new and existing) energy systems. It allows users to explore energy system scenarios for a one-year period with an hourly time resolution.

EnergyPLAN has been developed and maintained by Aalborg University since 1999, and the evolving role of renewable energy technologies in the tool is well documented. In 2004, the tool focused on modelling only wind, solar and heat pump technologies. By 2009, however, storage options were added (*e.g.*, battery, compressed air energy storage and hydrogen storage), along with transport options, electrolyzers and cooling technologies. Waste-to-energy, geothermal, absorption heat pumps, pumped hydropower, biomass conversion and synthetic gas technologies were added by 2012, alongside grid considerations. By 2017, additional desalination, carbon capture and district cooling features were added as well.

Today, EnergyPLAN models all key renewable energy technologies, conventional energy technologies and storage technologies.

A wide range of studies, from urban to international scales, have been undertaken using EnergyPLAN (Aalborg University, 2018). Most studies focus on the integration of renewable energy technologies into energy systems. The geographic focus is mostly on European countries, but applications exist in the US, Africa (*e.g.*, Kenya and Tanzania), Central America (Mexico) and China (Hong Kong).

With respect to urban-scale studies, in the case of Denmark strategies for 100% renewable energy were developed for Aalborg, Copenhagen, and Samsø, and the transformation of district heating to use renewable sources was investigated for Frederikshavn. Integrated energy systems and local Danish energy markets were also investigated. Additional studies have focused on renewable energy integration to make neighbourhoods self-sufficient in the Netherlands, on renewable energy integration in Humboldt, California, US and on renewable energy scenarios in Hong Kong.

**Considering:** EnergyPLAN represents all renewable energy technologies, but with limited technical detailing compared to most other recommended urban energy planning and modelling tools. It can represent multiple-input/output processes with basic parameters (*e.g.*, efficiency), but it does not consider availability (*e.g.*, for maintenance planning or forced outages), curtailment, ramping rates, unit commitment or the possibility to retire sub-optimal assets, among others. The time step is fixed to one hour, which is suitable for many renewable energy applications. However, EnergyPLAN represents all costs, including the possibility to have fixed or variable (*i.e.*, hourly) commodity costs. All renewable energy resources can be specified on the supply side as well.

**Identifying:** EnergyPLAN is a bottom-up, deterministic simulation model designed to help users explore different energy scenarios, with a strong focus on renewable energy technologies. Its primary use is to analyse the operation of these technologies rather than to optimise investments.

To this end, different policy mechanisms and regulation strategies can be represented within relatively limited, short-term time horizons. The tool is not designed for long-term analysis, although the modeller can link individual single-year runs to simulate a longer term. It is also not well-suited for incorporating uncertainty or life-cycle analysis, and only CO<sub>2</sub> emissions are considered. The omission of these aspects limits the range of EnergyPLAN's applications; nonetheless, its ability to quickly evaluate and compare many energy scenarios has been harnessed to map out renewable energy pathways for multiple cities.

**Integrating:** EnergyPLAN can represent all sectors of a city in a single-region model. Renewable energy integration can also be evaluated with a range of electricity and heat storage devices, although the storage models are not as detailed as in other evaluated models. All end-use demands are considered, but heat demand is aggregated (*i.e.*, a breakdown by different heating types, such as domestic hot water and process heat, is not available). However, demand elasticity can be specified. Although system interactions are represented in a city energy model, network representation is modelled very simply. Imports and exports are considered, but network elements or capacities cannot be represented.

These factors limit how thoroughly users can evaluate the feasibility of renewable energy integration in a city's energy system.

**Scaling:** EnergyPLAN is suitable for both greenfield and brownfield studies in cities, although it cannot represent all the details of a city's energy system (*e.g.*, networks). The model performs simulations for one year at a time, sufficient to evaluate or optimise an energy system design aiming at scaling of renewable energy technologies into the future; however, several yearly simulations can be combined to approximate a medium-term scenario.

**Usability:** One of EnergyPLAN's strengths is its user-friendliness. It is a free tool with a well-developed graphical user interface and transparent documentation. As a free tool, technical support is limited, but the tool is widely used around the world and requires only a few days of training to get started. It does not come with a supporting database, but it helps users get started with default suggestions for technology parameters.

**Overall:** EnergyPLAN can be a useful tool for urban energy planners to quickly explore a range of renewable energy scenarios and policies within a short time horizon. The operational insights on renewable energy technologies from EnergyPLAN can be combined powerfully with other tools (*e.g.*, using EnergyPLAN to analyse the operational performance of an optimal technology mix in each year based on results from a long-term capacity optimisation model such as OSeMOSYS). EnergyPLAN is also user-friendly for both practitioners and experts.



## HOMER

**Basic description:** HOMER (Hybrid Optimization of Multiple Energy Resources) is one of the most popular tools for local-scale energy systems modelling. It provides a bottom-up simulation and enumerative optimisation tool, meaning that it simulates all possible system configurations under the given constraints and characteristics, and then identifies optimal solutions. HOMER targets stand-alone and grid-connected power systems modelling and allows for simulations down to a minute level for a one-year period.

The increasing importance of renewable energy technologies, storage solutions and environmental concerns in today's energy systems is evidenced by HOMER's continual evolution over time. In 2000, the ability to account for emissions was added to the model, and by 2005 additions included new technologies (hydropower, biomass and hydrogen converters), improved battery storage modelling, hydrogen storage, real-time grid pricing, emission constraints and penalties, and more detailed results for all renewable energy technologies. Given its focus on renewable integration, HOMER enabled simulation time steps of down to one minute in 2007, along with the ability to model temperature effects on PV and new grid/battery control parameters.

By 2015, the tool had made notable storage modelling improvements, including the ability to model flywheel storage, specifying the initial battery state-of-charge, and adding more than 50 new battery models. Modelling improvements were also made for solar and wind energy systems (e.g., expanded maximum power point tracker capabilities for solar and temperature effects on wind resources). Since 2015, a new hydrogen module has been added, along with advanced grid features (e.g., scheduled outages and per-rate options) and a greatly expanded component library.

Myriad studies from around the world have utilised HOMER. Examples of optimal renewable energy technology planning for new systems, including micro-grid applications and hybrid systems, are presented for urban communities in India (Fulzele and Dutt, 2012; Phurailatpam *et al.*, 2018; Kumar and Bhimasingu, 2014). In China, a hybrid solar-wind energy system for a grid-connected micro-grid is investigated in Liu *et al.* (2013). African applications include the integration of renewable energy technologies for water-stressed urban areas in sub-Saharan Africa (Brandoni and Bošnjaković, 2017).

US-based studies include optimally designing a hybrid PV-wind-storage system for Catalina Island, storage integration with wind energy at various sites in California and distributed renewables integration into family households in Boulder, Colorado (Huang *et al.*, 2011; Lipman *et al.*, 2005; Johnson *et al.*, 2011).

Finally, in Europe, urban tri-generation and teleheating systems were investigated for a community near Rome, Italy (Salata *et al.*, 2015).

System models need to reflect the increasing use of renewables and storage solutions, along with rising environmental concerns over time.

**Considering:** HOMER employs one of the most highly detailed approaches for modelling renewable energy technologies in this study. It is one of the few tools that allows for analysis on a sub-hourly (*i.e.*, down to a minute) level, which is useful for detailed dispatch analysis of renewables. It also considers low-level technology details; for instance, maximum power point tracking, temperature effects on performance, and panel orientation (*e.g.*, azimuth and slope) for solar PV; head and flow rates for hydropower; and hub height, air density and Weibull distributions for wind turbines.

Renewable energy curtailment options and detailed cost models are also included. HOMER's strength in modelling is closely linked to its limitations. HOMER is useful for urban renewable energy project analysis but is not intended to model an entire city, or for long-term analysis. It also focuses on distributed electricity generation and does not model all conventional energy technologies. Still, HOMER is a powerful analytical tool for urban energy planners who want to pursue a renewable energy project in a city and require investment and operational decision-making support.

**Identifying:** HOMER is designed to help planners identify the optimal sizing and operation of a renewable energy system by using an enumerative optimisation approach. It also supports uncertainty analysis through its method. HOMER allows users to assess a range of policy measures (including carbon taxes, emission targets and tariff schemes), but only over one year. It is not designed for scenario modelling; rather, its strength lies in project sizing and operation.

**Integrating:** As HOMER is focused on system analysis of renewable energy technologies, it is atypical in the set of considered tools. It focuses on the electricity sector and does not explicitly model multiple city sectors and their interactions.

One of HOMER's strengths in analysing how renewable energy technologies can be integrated into energy systems lies in storage modelling. Several types of electricity storage devices can be modelled with significant technical detailing (*e.g.*, rate-dependent losses, changes in capacity with temperature, variable depth-of-discharge for cycle life and increased degradation rate at higher temperatures). HOMER also has a grid model, which is not a power flow model but considers factors like security (*e.g.*, outages, grid resilience and reliability) that most urban energy planning and modelling tools do not.

**Scaling:** HOMER is suitable for both greenfield and brownfield analyses for renewable energy projects in urban environments. Although it is not suitable for modelling an entire city's energy system, the size of a project is not limited. Its short time steps make the tool suitable for only short-term (up to one year) analysis.

**Usability:** HOMER has a well-developed graphical user interface with supporting resource and component libraries/databases. As a commercial tool, it comes with strong technical support, and although its code is not open source, the underlying calculations are transparent in documentation. The suggested training period for users to get started is short (1-2 days).

**Overall:** HOMER is a powerful tool for analysing urban renewable energy projects, providing in-depth investment and operational decision support to energy planners. Most other tools in this study focus on city-wide energy systems modelling and integration of renewable energy technologies, but these approaches do not offer the level of technical detailing that HOMER does. HOMER fills this gap and is thus an asset as part of a broader tool set for urban energy planners. It can provide low-level analysis after higher-level studies have been completed and a city has decided to implement a renewable energy project.

## TIMES

**Basic description:** TIMES (The Integrated MARKAL-EFOM System) is part of the MARKAL family of models, developed and maintained by the International Energy Agency since 1980. It is another of the most widely utilised energy planning modelling tools, applied on all scales from local to global. More than 300 institutions in more than 80 countries currently use TIMES.

TIMES is a least-cost linear optimisation, partial equilibrium model that can be used for a wide range of analyses. The modelling framework provides users with the freedom to define any process, including all technology types, for time steps down to an hour and for any number of years into the future. It is particularly suitable for long-term energy systems planning and policy analysis.

Several local-scale studies have employed TIMES. In Europe, the tool has been applied to investigate long-term decarbonisation pathways through increased local uptake of renewable energy technologies for suburban and urban municipalities across Switzerland. It was also used to model household behaviour impacts on the French residential and transport sectors, to model energy scenarios for an Italian seaside town and to reduce emissions in a city transport sector model (Cayla and Maïzi, 2015); Forsberg & Krook-Riekkola, 2017). In the US, TIMES was used to investigate the environmental and economic impacts of introducing a carbon tax in Long Island and for low-carbon/renewable energy pathways in New York City (Cayla and Maïzi, 2015; Bhatt *et al.*, 2010).

**Considering:** TIMES, much like OSeMOSYS, offers highly flexible modelling options for renewable and other energy technologies. It offers all of the technical modelling strengths discussed for the OSeMOSYS model (as OSeMOSYS is based heavily on TIMES), including customisable multi-input/output technologies, availability factors by time slice, ramping rates, flexible time slices down to an hourly level, renewable energy curtailment and technology ageing. Full-cost modelling, variable hourly prices (*e.g.*, for electricity) and feed-in tariffs can also be specified, which are important for analysing renewable energy technologies. As with OSeMOSYS, ambient effects on technology performance are not modelled in TIMES.

**Identifying:** The least-cost linear optimisation of TIMES is like the approach of OSeMOSYS, along with its limiting assumptions of perfect foresight, perfect markets and a single cost minimisation objective. However, TIMES has a stochastic extension for uncertainty analysis and can incorporate life-cycle impacts through auxiliary commodities, which are interesting analytical aspects when considering renewable energy technologies. TIMES is useful for optimal long- or short-term renewable energy capacity and dispatch planning, and can use both linear and mixed-integer linear programming for sizing of technologies. The idea behind TIMES (like OSeMOSYS) is to explore future energy pathways through different scenarios (*e.g.*, low-carbon and high renewable energy scenarios). TIMES can be used to investigate a wide range of policy scenarios to encourage renewable energy, including the use of carbon taxes, emissions targets, subsidies, feed-in tariffs and time-of-use rates.

**Integrating:** TIMES shares the same advantages as OSeMOSYS in this respect. All city sectors, scales, technologies and interactions can be modelled to provide a holistic analysis of renewable energy integration. Any demand and supply resource (including renewables) can be represented, and a city can be modelled as various interactive regions. Although network connections and energy trading can be represented, TIMES is not a detailed power flow model (neither in terms of time scale nor network details). Storage models are more advanced in TIMES than OSeMOSYS; however, they are still limited by technical detailing (e.g., temperature effects and rate-dependent losses are not included) and by limited flexibility of storage cycling between time slice levels (e.g., between daily and monthly levels).

**Scaling:** As with OSeMOSYS, TIMES can be used to create an energy model for any scale, from buildings to aggregated city sectors. It is useful for both long-term capacity and dispatch planning, and for both greenfield and brownfield analyses. Economies of scale for renewable energy technologies can also be incorporated into models.

**Usability:** Perhaps the largest difference between TIMES and OSeMOSYS is its cost of use. TIMES is a more developed tool, which offers greater modelling flexibility and features; however, a licence to use front-end interfaces can cost up to USD 20 000 per year. Although it has a user interface, TIMES typically requires more training than most modelling tools to harness its full potential, and it appeals to modellers with a strong technical background and skill set. The TIMES code itself is written in GAMS and is open source, allowing expert users to develop it further. Users must supply all model input data, and technical support is available mostly through community forums.

**Overall:** TIMES is a powerful, commercial optimisation tool that can model an entire city's energy system in order to identify cost-optimal integration pathways and policies for renewable energy technologies in the long term. The tool is more developed and has more capabilities than OSeMOSYS, but this comes at a cost that can be prohibitive to users with budget constraints. It is also designed for more experienced modellers, having the longest recommended training period of all models in this study (one to three months).

## MESSAGE

**Basic description:** MESSAGE (Model for Energy Supply Strategy Alternatives and their General Environmental Impact) is a widely used integrated assessment modelling tool. It was developed by the International Institute for Applied Systems Analysis (IIASA) and has been in use since the 1980s.

MESSAGE is a least-cost linear optimisation, partial equilibrium model that supports long-term scenario assessment and investment decision making. There are several MESSAGE variants. Most recently, the MESSAGEix model was developed, which is a more versatile, open-source implementation of MESSAGE. MESSAGEix allows for modelling all energy technologies down to an hourly scale and is suitable for urban-scale modelling.

The MESSAGE model has been adapted to evolving energy technologies and growing environmental concerns over the course of four decades (Huppmann *et al.*, 2019). A stochastic implementation to analyse risks was also developed around this time. In 2006, IIASA developed a detailed accounting of pollutants for emissions analysis, and in the mid-2010s researchers developed methodologies to address challenges with VRE technologies (Johnson *et al.*, 2017).

MESSAGE has traditionally been applied on the national and global level; however, MESSAGEix is a flexible tool that is applied on any scale. Local-level applications of MESSAGE for India are described for the Indus region and to study household energy consumption (IIASA, 2018).

**Considering:** MESSAGE (MESSAGEix) can permit detailed modelling of renewable energy technologies with similar technical detailing as mentioned for the TIMES tool. As with many other energy models, the technical performance of technologies is not affected by ambient conditions such as temperature or part-load conditions. Time steps can be defined flexibly down to an hourly level, and all technology costs are considered.

**Identifying:** MESSAGE is also a perfect foresight, linear cost optimisation model with the inherent weak assumption of perfect conditions. However, the core MESSAGE model can interface with several other packages and modules, including the MESSAGE Robust Decision-Making Framework for decision making under uncertainty. MESSAGE, like TIMES, is useful for identifying cost-optimal capacity planning pathways for renewable energy technologies by evaluating different long-term scenarios in cities, including emissions targets and a wide range of energy policies. It, too, can represent economies of scale over time and size systems using linear or mixed-integer programming.

**Integrating:** MESSAGE can be used to model a city's complete energy system, with all sectors, any energy demand commodity, and all supply resources, to thoroughly assess the integration of renewable energy technologies. Cities can be modelled as multiple interactive regions that exchange energy and have basic network connections. Demand elasticity and response can be analysed using MESSAGE as well. All storage types can be modelled to aid the integration of renewable technologies, but these models are not as technically detailed as in HOMER. MESSAGEix also incorporates a generic land-use model emulator that can be useful for exploring land-use constraints in renewable energy systems integration in cities.

**Scaling:** MESSAGE is appropriate for both greenfield and brownfield analyses for cities on any scale (lower-scale building/neighbourhood-level analyses are atypical, however). The tool's focus on long-term, multi-year investment and operational planning enables it to scale renewable energy technologies in urban energy systems appropriately.

**Usability:** MESSAGEix is a new, free, open-source tool that builds on the core MESSAGE model. (The original MESSAGE model is free only to academics and member states of the International Atomic Energy Agency.) The tool was developed to “allow more efficient scientific workflows and direct integration with external data sources and other models or tools”, as well as to provide users with the flexibility to add new equations and parameters for specific use cases (such as representing renewables, emissions accounting or life-cycle assessments) (Huppmann *et al.*, 2019).

Hence, MESSAGEix provides considerable technical flexibility. It has a web-based interface, although users are expected to have a strong technical background. Training times are estimated to be around two weeks.

**Overall:** MESSAGEix is another powerful, free optimisation tool that users around the world can employ to support long-term renewable energy and policy planning in cities. It is also unique in offering the ability to assess land-use scenarios using its land-use emulator.

MESSAGEix is particularly interesting for advanced users, who enjoy considerable technical freedom in customising and integrating the tool with other platforms (including other MESSAGE models) and tools to harness its full analytical power. It also has a shorter recommended training time than TIMES.



## LEAP

**Basic description:** The LEAP (Long-range Energy Alternatives Planning) model is another of the most widely used energy system modelling tools today, with more than 36 000 users in 195 countries (SEI, 2019). It is primarily a simulation tool used to explore long-term scenarios, but it also offers optimisation capabilities through interfacing with the OSeMOSYS tool.

LEAP is employed by a wide range of users (including government, non-government, research, consulting and energy utility users) for energy policy and climate change mitigation strategy analysis, from the local to the global scale. It was developed in 1980 by the Stockholm Environment Institute and has seen various changes over the past four decades. As the environmental impact of energy systems became a growing concern in the 1990s, LEAP added an environmental database (funded largely by the UN) and became one of the first tools to address this issue in energy systems modelling. By the mid-1990s, LEAP greenhouse gas mitigation assessment capabilities were developed even further, and LEAP was used by numerous countries in their communications with the UNFCCC. In 2004, multi-region modelling capabilities were introduced.

Many local-scale applications of LEAP exist, a small selection of which are described here. In China, LEAP has been used to explore low-carbon (including renewable energy) transition pathways for Beijing and to decarbonise the transport sector in Tianjin (Zhang *et al.*, 2011; Yu *et al.*, 2015; Peng *et al.*, 2015).

Urban transport decarbonisation strategies have been investigated for Indian metropolises, and low-carbon electricity and residential sector scenarios were developed for Delhi and Maharashtra (Kadian *et al.*, 2007; Kale and Pohekar, 2014). Nepal has investigated sustainable urban transport pathways for Kathmandu (Dhakal, 2006). LEAP also has been applied in Africa, where the SAMSET project uses it to support African municipalities in developing sustainable energy strategies, including sustainable development pathways for two municipalities in Uganda (Kasese and Jinja) (Mann *et al.*, 2015). In the US and Europe, LEAP has been used to develop energy and climate-related strategies and action plans to achieve carbon neutrality at the sub-national level (Beaton, 2015; Lazarus *et al.*, 2011).

**Considering:** LEAP can model all renewable energy technologies and their fundamental technology characteristics. It is not as extensive and flexible in its technical representation as other tools; for example, users are restricted by drop-down menu options and are limited to basic technology features, such as efficiency and annual availability. Technology costs include capital costs, fixed and variable operation and maintenance costs, and stranded and salvage costs. LEAP is designed for simulation analysis using annual time steps, but it also integrates with OSeMOSYS to provide optimisation analysis down to an hourly level. Additional technology parameters can be specified through the OSeMOSYS interface (e.g., higher resolution availability factors). When used as a simulation tool without OSeMOSYS, the analysis for VRE technologies is limited by an annual time step.

**Identifying:** LEAP is a simulation tool designed to explore medium- to long-term energy scenarios. Several cities and regions (e.g., Copenhagen, Seattle and the US state of Massachusetts) have used LEAP to help develop concrete climate and energy action plans for their cities.

LEAP enables urban energy planners to evaluate a range of energy policies and carbon emissions reduction targets to promote renewables. However, the tool is limited by perfect foresight assumptions (as are most energy models), and it is not designed for stochastic or uncertainty analysis (although sensitivity analyses can be performed).

Its annual time step and underlying simulation and accounting methods also means that certain policies (e.g., time-of-use electricity pricing) and optimal energy planning cannot be made without the support of other modules or tools (like OSeMOSYS). An annual time step limits the analysis of VRE technologies, storage and other energy system interactions.

**Integrating:** LEAP can be used to build a city-wide model to evaluate the role of renewable energy technologies in long-term scenarios. The model can include all sectors, end-use demands and supply resources (including renewables), although users must select from pre-defined categories (i.e., users cannot specify custom commodities). A city can also be split into multiple regions.

LEAP is not designed for storage modelling (given its annual time resolution), although storage models may be incorporated using the OSeMOSYS extension. Network specifications are very basic as well (i.e., as net losses rather than as explicit technologies). However, net energy trading (imports/exports) can be tracked.

Analysis of the integration of renewable energy technologies in a city will be limited by these factors when using LEAP; however, the tool is well suited for “big picture” analyses, whereby users can explore many scenarios for a city, often without having to have a complete and detailed input data set (discussed further in the usability section below).

**Scaling:** LEAP is more suited to long-term, brownfield analyses on city-wide scales, rather than for greenfield renewable projects in the short term in small districts. Yet smaller city blocks can be evaluated as well. The base model, however, does not seem to allow either the scaling or varying of future costs or the representation of economies of scale.

**Usability:** LEAP is a relatively user-friendly tool with a well-developed graphical user interface and a large online support community. It is free to all students and to non-profit groups, governments and academics in developing countries; however, it is not open source, and documentation explaining its underlying equations and assumptions appears to be limited. One of LEAP’s usability strengths is that it has low initial data requirements (often one of the key barriers in energy modelling). Users with limited data may start building models using simple accounting methods, and can gradually layer in data complexity according to their needs and data availability. LEAP also supports users with a technology and environmental database. It interfaces well with other tools and generally requires less than a week of training.

**Overall:** LEAP is a popular simulation and scenario modelling tool among urban climate and energy strategists. It is well supported, user-friendly and suitable for both urban energy planning practitioners and experts. It is limited in its analytical scope due to its use of annual time steps and a lack of technological detailing; however, it provides options for more detailed analyses by interfacing with powerful tools like OSeMOSYS, and through its own extensions.



### 4.3 Modelling challenges for developing countries

Most developing country energy system models adopt modelling methods from industrialised countries. Since these approaches are mostly designed by and for developed countries, they tend to neglect several characteristics pertinent to developing countries. Neglecting these factors limits the efficacy of these models for energy planning purposes. The sections that follow detail the various challenges that existing methods face in representing energy systems (including urban energy systems) in developing countries. A summary of contributing factors and barriers is given at the end of the section.

#### MODELLING POOR POWER SECTOR PERFORMANCE

Many developing countries struggle with poor power sector management and performance. Power system configurations are often sub-optimal and unable to meet local demand, even when excess capacity exists. This can be due to faulty planning and poorly performed operation and maintenance that leads to plant breakdowns, voltage and frequency fluctuations, power outages, load shedding and other grid security issues. Inadequate supply-side performance can also be attributed to rapidly growing demand under insufficient generation capacity, poor financing, high technical and non-technical losses, and other organisational problems.

Poorly designed pricing mechanisms lead to significant losses in the power sector of many developing countries. Tariffs may sometimes fall below long-term marginal production costs or even average operating costs.

The lack of effective revenue collection results in large losses as well; a significant share of unpaid electricity bills is not collected because governmental departments and government-owned companies enjoy government protections, which means that they can avoid repercussions for unpaid utility bills.

In India, electricity theft through unpaid bills, tapped grid lines, and transmission and distribution losses accounts for almost 30% of power generation (compared to an average loss of 6% in member countries of the Organisation for Economic Co-operation and Development); this has placed the Indian power sector at a serious risk of bankruptcy (Urban *et al.*, 2007).

The inadequate use of subsidies also creates financing challenges, such as market distortions and limited competition. Financing mechanisms such as subsidies are also meant to incentivise renewable energy adoption in cities, but their effectiveness is impeded under poor management.

Many urban energy planning and modelling frameworks assume perfect conditions, markets and foresight (*e.g.*, OSeMOSYS, TIMES, MESSAGE, LEAP, Balmorel and EnergyPLAN). These assumptions raise doubts in the best of cases, let alone under the aforementioned conditions. To develop meaningful results, energy system models need to represent power sector problems either explicitly in technical representations (*e.g.*, through low availability factors or other performance specifications) or implicitly in energy modelling scenarios.

## REPRESENTING INFORMAL AND TRANSITIONAL ECONOMIES

The informal economy consists of all unofficial transactions (monetary and non-monetary) that are not captured in official economic descriptions such as GDP or value added. Its size can be significant in developing countries. However, few, if any, energy system models explicitly consider the informal economy when describing energy economic systems. Consideration of informal factors is important for estimating future demand, representing energy system economies and generating meaningful results to inform decision making.

Developing countries are often assumed to follow the same development pathway as today's industrialised countries – that is, shifting from a decline in agriculture to a large industrial sector and then towards the service sector. However, many Asian developing countries have followed a lower energy intensity path than expected through an early shift to the service sector (for example, in India). This is an important consideration in long-term energy demand scenarios for developing countries and cities.

The biggest challenge in representing informal and transitional economies in developing countries is a lack of data. Data are difficult to collect as the informal economy can include illegal activities, tax evasion or avoidance, and monetary and non-monetary transactions. There may also be limited political willpower to collect data in this direction.



### MODELLING CHALLENGES AND THE INTEGRATION OF RENEWABLES

Energy models for developing urban energy system plans that neglect to consider the aforementioned factors are limited in their ability to provide meaningful planning suggestions for renewable energy technologies.

Studies have analysed a wide range of local and larger-scale project failures in developing countries, which are attributed to, among other factors, project mismanagement, corruption, operational failures, poor maintenance, investment failures, inadequate government support and insufficient capacity building at the local scale (Okereke, 2017; Ikejemba *et al.*, 2017).

Given these failures, integration of renewable energy in cities, especially in combination with innovative technologies and management strategies (such as smart grids and demand-side management), requires careful modelling and analyses to determine realistic implementation costs, benefits and risks.

This is also important to attract investors in renewable energy projects, who will be better convinced of modelling results that consider the social, technical and economic factors/risks. That said, cities should not be overly concerned about the grid stability and reliability issues posed by their first batch of VRE projects, as the utility typically should cope with the associated operational challenges. As the shares of variable renewables grow to certain levels, modelling would become more useful and necessary.

There are several factors behind the aforementioned gaps and challenges in modelling for developing countries. Most developing country energy models adopt approaches established by and applied in developed countries. Since the latter countries do not experience these factors as acutely, they are often neglected in modelling. The literature emphasises the existence of these modelling gaps for developing countries, but the methods to model them are underdeveloped. There is a lack of collaborative research between developed and developing countries to establish methods to include these aspects in energy system models.



#### 4.4 Looking forward in urban energy system planning

Looking forward, with rapid urbanisation and the growing impact of global climate change at the local level, cities should pay greater attention to the following elements in long-term urban energy systems planning, including urban densification, local energy resource integration, efficiency in the built environment, microclimates and climate change, and transport infrastructure changes.

##### URBAN DENSIFICATION

Future cities are expected to experience steadily increasing urban density. Denser cities translate to more efficient land use, reducing the need for private cars and leading to more tightly integrated mass-transit systems. They also reduce city-wide energy demand and greenhouse gas emissions in both developed and developing countries (Güneralp *et al.*, 2017). However, “densification” can also potentially lead to greater congestion and increased localised air pollution. Land-use transport models combined with urban energy planning and modelling tools can help researchers evaluate urban densification effects and their energy impacts.

##### LOCAL ENERGY RESOURCE INTEGRATION

With rising urban populations and densification, local resource management and its integration into energy systems will become increasingly relevant as well. Resource streams, such as wastewater, sewage and other solid waste generated by inhabitants, should be integrated into urban energy system planning. This is particularly important in developing country cities where 60–80% of solid waste is organic. An estimated 90% of this waste could be converted into something useful, such as biogas; however, local governments currently spend 30–40% of their budgets on waste management systems that provide few such gains (Heyzer, 2014). Such untapped resource streams must be integrated into urban renewable energy planning models.

##### EFFICIENCY IN THE BUILT ENVIRONMENT

Increased efficiency of energy use in the built environment (through retrofitting, renovations and higher efficiency standards for new buildings) is another key feature of future cities. Many urban energy planning and modelling tools do not explicitly model building efficiency measures, although modellers can represent them using workarounds (e.g., by modelling building renovations as artificial supply technologies to reduce building end-use demand). Still, these tools would benefit from more explicit approaches to representing building efficiency measures in models.

## MICROCLIMATES AND CLIMATE CHANGE

Microclimates and urban heat island effects are not often considered in energy system models, yet they can have significant local impacts. Urban heat island effects can raise city temperatures by up to a few degrees Celsius, which impacts the cooling and heating energy demand of buildings (Masson *et al.*, 2014; Santamouris, 2014). Thus, neglecting urban heat island effects in models can lead to under-estimations of cooling demands and over-estimations of heating demands. This leads to inaccurate results and sub-optimal planning decisions by urban energy planning and modelling tools.

Global climate change impacts on local energy systems also need to be considered in long-term energy models. The immediate effect of global temperature rise is a significant increase in the cooling demand of buildings; for example, Ortiz *et al.* (2018) found that summer cooling demand in New York City could be almost 30% higher by the end of the century compared to the 2006–2010 period. In addition to changes in demand, cities must grapple with climate impacts on urban economic growth, resource scarcity and demographic changes.

## TRANSPORT INFRASTRUCTURE CHANGES

Technology changes in the transport sector have potentially significant impacts on urban planning. For instance, with the increased adoption of electric mobility in developing countries, cities will need to build new charging infrastructure, which ideally would be powered by renewable energy sources. Autonomous driving and car-sharing programmes can also integrate with mass-transit systems to alleviate congestion and reduce the demand for private vehicles, along with their associated land and fuel use. Future transport networks may be intelligently managed using sensors and drones as well; these systems would integrate with vehicles and other transport systems to improve traffic congestion, energy efficiency and safety.

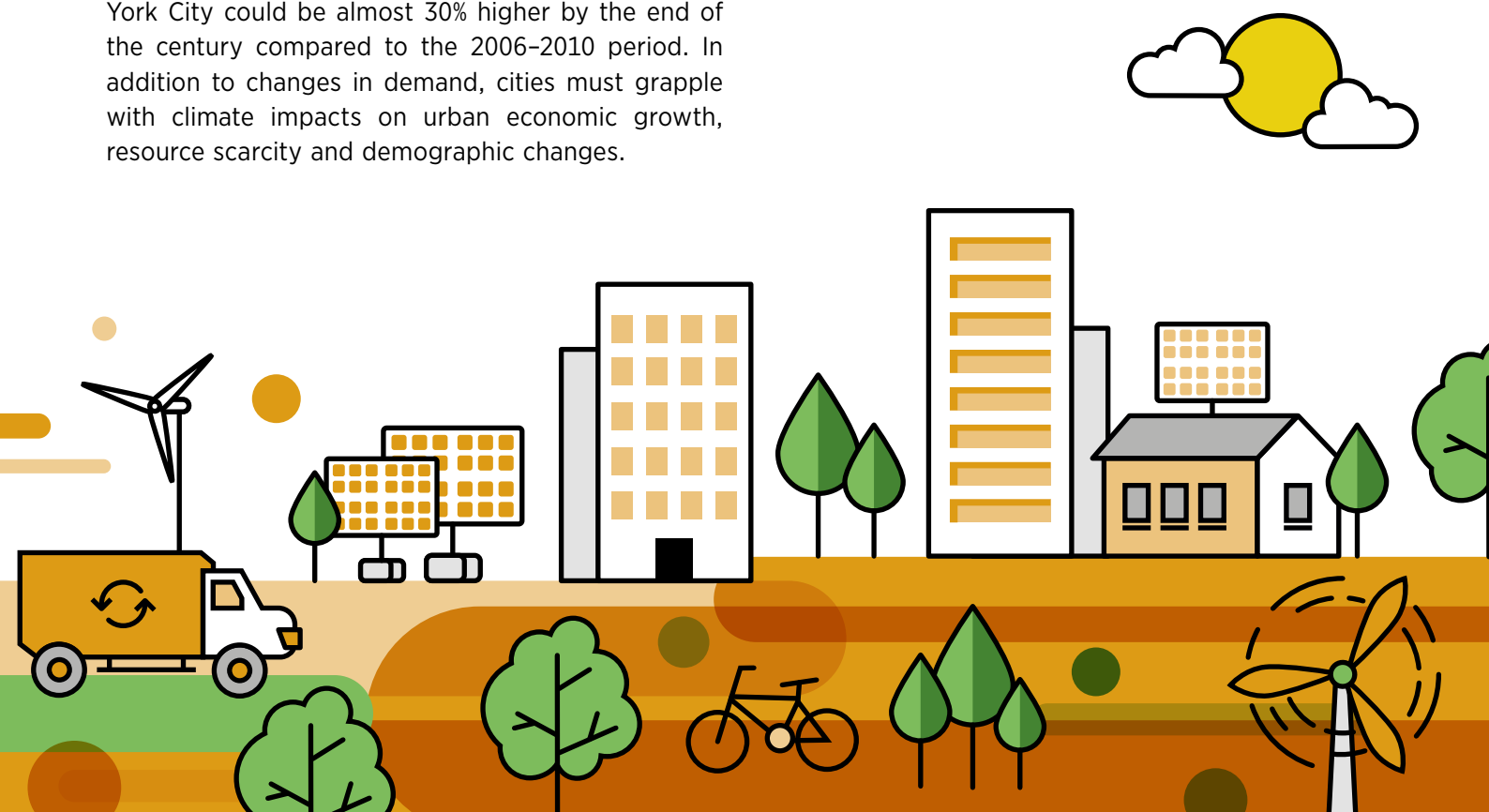

# References

- 100% Renewable Energy Atlas (2019a)**, “City, town, village”, [www.100-percent.org/city-town-village](http://www.100-percent.org/city-town-village) (accessed 3 December 2019).
- 100% Renewable Energy Atlas (2019b)**, “Las Gaviotas, Colombia”, [www.100-percent.org/las-gaviotas-colombia](http://www.100-percent.org/las-gaviotas-colombia) (updated 20 February 2019).
- 100% Renewables (2019)**, “100% renewables map”, go100RE, [www.go100re.net/map](http://www.go100re.net/map) (accessed September 2019).
- Aalborg University (2018)**, “EnergyPLAN—all case studies”, Aalborg University, Aalborg, [www.energyplan.eu/category/allcasestudies](http://www.energyplan.eu/category/allcasestudies).
- Al Seadi, T. et al. (2008)**, *Biogas Handbook*, University of Southern Denmark Esbjerg, Esbjerg, Denmark, [www.lemvigbiogas.com/BiogasHandbook.pdf](http://www.lemvigbiogas.com/BiogasHandbook.pdf).
- Al-Waeli, A.H.A. et al. (2017)**, “Photovoltaic thermal PV/T systems: A review”, *International Journal of Computation and Applied Sciences*, Vol. 2/2, Sutton, Surrey, pp. 62–67.
- Bachmann, N. (2015)**, *Sustainable biogas production in municipal wastewater treatment plants*, International Energy Agency Bioenergy, Paris, [www.iea-biogas.net/files/daten-redaktion/download/Technical%20Brochures/Wastewater\\_biogas\\_grey\\_web-1.pdf](http://www.iea-biogas.net/files/daten-redaktion/download/Technical%20Brochures/Wastewater_biogas_grey_web-1.pdf).
- Barbose, G. and D. Darghouth (2019)**, *Tracking the sun: Pricing and design trends for distributed photovoltaic systems in the United States*, Lawrence Berkeley National Laboratory, Berkeley, California, <https://emp.lbl.gov/publications/tracking-sun-pricing-and-design>.
- Bayer, P. et al. (2019)**, “The geothermal potential of cities”, *Renewable and Sustainable Energy Reviews*, Vol. 106 (May), Elsevier, Amsterdam, pp. 17–30.
- Beaton, M.A. (2015)**, *Massachusetts clean energy and climate plan for 2020*, Executive Office of Energy and Environmental Affairs, State of Massachusetts, Boston, Massachusetts.
- Beck, H. et al. (2018)**, “Present and future Köppen-Geiger climate classification maps at 1-km resolution”, *Scientific Data*, Vol. 5, Springer Nature, London.
- Bellini, E. (28 April 2020)**, “Abu Dhabi’s 1.5 GW tender draws world record low solar bid of \$0.0135/kWh”, *pv magazine*, [www.pv-magazine.com/2020/04/28/abu-dhabis-2-gw-tender-draws-world-record-solar-bid-of-0-0135-kwh](http://www.pv-magazine.com/2020/04/28/abu-dhabis-2-gw-tender-draws-world-record-solar-bid-of-0-0135-kwh).
- Bellos, E. et al. (2016)**, “Exergetic, energetic and financial evaluation of a solar driven absorption cooling system with various collector types”, *Applied Thermal Engineering*, Vol. 102 (June), Elsevier, Amsterdam, pp. 749–759.
- Bhatt, V. et al. (2010)**, “Integrated energy and environmental systems analysis methodology for achieving low carbon cities”, *Journal of Renewable and Sustainable Energy*, Vol. 2/3, AIP Publishing, Melville, New York, p. 031012.
- Brandoni, C. and B. Bošnjaković (2017)**, “HOMER analysis of the water and renewable energy nexus for water-stressed urban areas in Sub-Saharan Africa”, *Journal of Cleaner Production*, Vol. 155 (July), Elsevier, Amsterdam, pp. 105–118.
- Brookings (2020)**, *Foresight Africa: Top priorities for the continent 2020–2030*, Brookings Institution, Washington, D.C., [www.brookings.edu/wp-content/uploads/2020/01/ForesightAfrica2020\\_20200110.pdf](http://www.brookings.edu/wp-content/uploads/2020/01/ForesightAfrica2020_20200110.pdf).

- Brown, D., S. Hall and M.E. Davis (2019)**, “Prosumers in the post subsidy era: an exploration of new prosumer business models in the UK”, *Energy Policy*, Vol. 135 (December), Elsevier, Amsterdam, p. 110984.
- Buonomano, A. et al. (2016)**, “Experimental analysis and dynamic simulation of a novel high-temperature solar cooling system”, *Energy Conversion and Management*, Vol. 109 (February), Elsevier, Amsterdam, pp. 19–39.
- Burmester, D. et al. (2017)**, “A review of nanogrid topologies and technologies”, *Renewable and Sustainable Energy Reviews*, Vol. 67 (January), Elsevier, Amsterdam, pp. 760–775.
- Byers, L. et al. (2019)**, *A global database of power plants* (database), World Resources Institute, Washington, D.C., [www.wri.org/publication/global-power-plant-database](http://www.wri.org/publication/global-power-plant-database).
- C40 Cities (2019)**, “About”, [www.c40.org/about](http://www.c40.org/about) (accessed 23 October 2019).
- C40 Cities (2011)**, *Case study: Waste to energy cuts 200,000 tCO<sub>2</sub> annually in Gothenburg*, C40 Cities, London, [www.c40.org/case\\_studies/waste-to-energy-cuts-200000-tco2-annually-in-gothenburg](http://www.c40.org/case_studies/waste-to-energy-cuts-200000-tco2-annually-in-gothenburg).
- Carbon Neutral Cities Alliance (2019)**, “Carbon Neutral Cities Alliance Members”, <https://carbonneutralcities.org> (accessed 23 October 2019).
- carbonn Center (2019)**, “The carbonn Center”, <https://carbonn.org> (accessed 23 October 2019).
- Cayla, J.M. and N. Maïzi (2015)**, “Integrating household behavior and heterogeneity into the TIMES-Households model”, *Applied Energy*, Vol. 139 (February), Elsevier, Amsterdam, pp. 56–67.
- CDIA (2020)**, “What is CDIA”, <https://cdia.asia/who-we-are/what-is-cdia> (accessed 31 March 2020).
- CDP (2019a)**, “2018 – Cities Renewable Energy Targets”, <https://data.cdp.net/Renewable-Energy/2018-Cities-Renewable-Energy-Targets/eai5-mrwy> (accessed November 2019).
- CDP (2019b)**, “Explore city, state and regional energy data and discover their progress towards low-carbon economies”, <https://data.cdp.net/browse?category=Renewable%20Energy> (accessed 12 March 2019).
- Chaliki, P., N.J. Themelis and C.S. Psomopoulos (2016)**, “WTE plants installed in European cities: A review of success stories”, *Management of Environmental Quality: An International Journal*, Vol. 27/5, Emerald Publishing, Melbourne, pp. 606–620.
- Chang, Y. and Y. Li (2014)**, *Non-renewable resources in Asian economies: Perspectives of availability, applicability, acceptability, and affordability*, Economic Research Institute for ASEAN and East Asia, Jakarta.
- Cilliers, J., B. Hughes and J. Moyer (2011)**, *African futures 2050: The next forty years*, Institute for Security Studies and Pardee Center for International Futures, Pretoria and Denver.
- Climate Mayors (2018)**, *Cities climate action compendium*, US Climate Mayors, Washington, D.C.
- Covenant of Mayors for Climate & Energy (2020)**, “Our cities”, [www.globalcovenantofmayors.org/our-cities](http://www.globalcovenantofmayors.org/our-cities) (accessed 20 January, 2020).
- Covenant of Mayors for Climate & Energy (2019)**, “Covenant community”, [www.covenantofmayors.eu/about/covenant-community/signatories.html](http://www.covenantofmayors.eu/about/covenant-community/signatories.html) (accessed 3 December 2019).
- Crouch, D. (11 March 2019)**, “Nordics tackle ‘Achilles heel’ of incineration power schemes”, *Financial Times*, [www.ft.com/content/21777666-248f-11e9-b20d-5376ca5216eb](http://www.ft.com/content/21777666-248f-11e9-b20d-5376ca5216eb).

- Data Driven Yale, NewClimate Institute and PBL (2018)**, *Global climate action from cities, regions and businesses*, Data Driven Yale, NewClimate Institute, PBL Netherlands Environmental Assessment Agency, [https://datadrivenlab.org/wp-content/uploads/2018/08/YALE-NCI-PBL\\_Global\\_climate\\_action.pdf](https://datadrivenlab.org/wp-content/uploads/2018/08/YALE-NCI-PBL_Global_climate_action.pdf).
- Davies, J.H. (2013)**, “Global map of solid Earth surface heat flow”, *Geochemistry, Geophysics, Geosystems*, Vol. 14/10, Wiley, Hoboken, New Jersey, pp. 4 608–4 622.
- del Amo, A. et al. (2017)**, “An innovative urban energy system constituted by a photovoltaic/thermal hybrid solar installation: Design, simulation and monitoring”, *Applied Energy*, Vol. 186, Elsevier, Amsterdam, pp. 140–151.
- Dhakai, S. (2006)**, *Urban transportation and the environment in Kathmandu Valley, Nepal: Integrating global carbon concerns into local air pollution management*, Institute for Global Environmental Strategies, Kanagawa.
- Dhimish, M. et al. (2018)**, “Preliminary assessment of the solar resource in the United Kingdom”, *Clean Energy*, Vol. 2/2, Oxford University Press, Oxford, UK, pp. 112–125.
- DIE (2020)**, *NDC Explorer* (database), German Development Institute, Bonn, [www.die-gdi.de/en/ndc](http://www.die-gdi.de/en/ndc), (accessed March 2020).
- Dilimulati, A., T. Stathopoulos and M. Paraschivoiu (2018)**, “Wind turbine designs for urban applications: A case study of shrouded diffuser casing for turbines”, *Journal of Wind Engineering & Industrial Aerodynamics*, Vol. 175 (April), Elsevier, Amsterdam, pp. 179–192.
- DNV GL (2019a)**, *Energy transition outlook 2019: A global and regional forecast to 2050*, DNV GL, Oslo, <https://eto.dnvgl.com/2019/index.html>.
- DNV GL (2019b)**, *Digitalisation and the future of energy*, DNV GL, Oslo, [www.dnvgl.com/power-renewables/themes/digitalization/index.html](http://www.dnvgl.com/power-renewables/themes/digitalization/index.html).
- Dreyfus, G. et al. (2020)**, *Assessment of climate and development benefits of efficient and climate-friendly cooling*, Lawrence Berkeley National Laboratory, Berkeley, California, [https://eta-publications.lbl.gov/sites/default/files/ilovepdf\\_merged\\_11.01.02\\_am.pdf](https://eta-publications.lbl.gov/sites/default/files/ilovepdf_merged_11.01.02_am.pdf).
- Dulal, H.B. et al. (2013)**, “Renewable energy diffusion in Asia: Can it happen without government support?” *Energy Policy*, Vol. 59 (August), Elsevier, Amsterdam, pp. 301–311.
- EASME (2019)**, “Overview: Building integrated photovoltaics (BIPV) as a viable option among renewables”, Executive Agency for Small and Medium-sized Enterprises, Brussels, [www.buildup.eu/en/news/overview-building-integrated-photovoltaics-bipv-viable-option-among-renewables](http://www.buildup.eu/en/news/overview-building-integrated-photovoltaics-bipv-viable-option-among-renewables).
- Ecoprog (2018)**, “Dynamic development of waste-to-energy market continues”, Ecoprog, Cologne, [www.ecoprog.com/fileadmin/user\\_upload/pressemitteilungen/ecoprog\\_press\\_release\\_Waste\\_to\\_Energy\\_2017-2018.pdf](http://www.ecoprog.com/fileadmin/user_upload/pressemitteilungen/ecoprog_press_release_Waste_to_Energy_2017-2018.pdf).
- Edenhofer, O. et al. (2014)**, “Technical summary”. In: *Climate Change 2014: Mitigation of Climate Change. Contribution of Working Group III to the Fifth Assessment Report of the Intergovernmental Panel on Climate Change*. Cambridge University Press, Cambridge, United Kingdom and New York, NY, USA, [www.ipcc.ch/site/assets/uploads/2018/02/ipcc\\_wg3\\_ar5\\_technical-summary.pdf](http://www.ipcc.ch/site/assets/uploads/2018/02/ipcc_wg3_ar5_technical-summary.pdf).
- Edo, M. and I. Johansson (2018)**, “International perspectives of energy from waste—challenges and trends”, *IRRC Waste-to-Energy Conference*, Vienna, pp. 47–61.
- EEA (2016)**, *Air pollutant emission inventory guidebook 2016*, European Environment Agency, Brussels, [www.eea.europa.eu/themes/air/air-pollution-sources-1/emep-eea-air-pollutant-emission-inventory-guidebook/emep](http://www.eea.europa.eu/themes/air/air-pollution-sources-1/emep-eea-air-pollutant-emission-inventory-guidebook/emep).
- Energy Cities (2018)**, *Cities heading towards 100% renewable energy*, Energy Cities, Brussels, [https://energy-cities.eu/wp-content/uploads/2018/11/publi\\_100percent\\_final-web\\_en.pdf](https://energy-cities.eu/wp-content/uploads/2018/11/publi_100percent_final-web_en.pdf).



- ESMAP (2012)**, *Geothermal handbook: Planning and financing power generation*, Energy Sector Management Assistance Program, World Bank, Washington, D.C., [www.esmap.org/sites/esmap.org/files/DocumentLibrary/FINAL\\_Geothermal%20Handbook\\_TR002-12\\_Reduced.pdf](http://www.esmap.org/sites/esmap.org/files/DocumentLibrary/FINAL_Geothermal%20Handbook_TR002-12_Reduced.pdf).
- Estrada, F. et al. (2017)**, “A global economic assessment of city policies to reduce climate change impacts”, *Nature Climate Change*, Vol. 7/6, Springer Nature, London, pp. 403–406.
- FERC (2008)**, *Assessment of demand response and advanced metering*, US Federal Energy Regulatory Commission, Washington, D.C.
- Forsberg, J. and A. Krook-Riekkola (2017)**, “Supporting cities’ emission mitigation strategies: Modelling urban transport in a TIMES energy system modelling framework”, *WIT Transactions on the Built Environment, Urban Transport XXIII*, WIT Press, Southampton, UK, pp. 15–25.
- Friedman, D.S. et al. (2012)**, “Environmental and economic impacts of a carbon tax: An application of the Long Island market model”, *Middle States Geographer*, Vol. 44, Middle States Division of the Association of American Geographers, pp. 18–26.
- Fulzele, J.B. and S. Dutt (2012)**, “Optimum planning of hybrid renewable energy system using HOMER”, *International Journal of Electrical and Computer Engineering*, Vol. 2/1, Institute of Advanced Engineering and Science, Yogyakarta, Indonesia, pp. 68–74.
- German Environment Agency (2008)**, *The role of waste incineration in Germany*, German Environment Agency, Dessau-Roßlau, [www.umweltbundesamt.de/sites/default/files/medien/publikation/long/3872.pdf](http://www.umweltbundesamt.de/sites/default/files/medien/publikation/long/3872.pdf).
- Gilmanova, A. and Y. Chen (24 February 2020)**, “China shapes future of global CSP development: From an international perspective”, China Energy News (中国能源报), [http://paper.people.com.cn/zgnyb/html/2020-02/24/content\\_1973108.htm](http://paper.people.com.cn/zgnyb/html/2020-02/24/content_1973108.htm) (in Chinese).
- Giugliano, M. and E. Ranzi (2016)**, “Thermal treatments of waste. Waste to energy (WtE)”, *Reference Module in Chemistry, Molecular Sciences and Chemical Engineering*, Elsevier, Amsterdam.
- Glasgow City Council (2014)**, *Sustainable Glasgow*, Glasgow, [www.smartcities-infosystem.eu/files/step-up\\_energy\\_and\\_carbon\\_masterplan\\_-\\_sustainable\\_glasgow.pdf](http://www.smartcities-infosystem.eu/files/step-up_energy_and_carbon_masterplan_-_sustainable_glasgow.pdf).
- Global Volcanism Program (2020)**, *Volcanoes of the World* (database), Smithsonian Institution Global Volcanism Program, <https://doi.org/10.5479/si.GVP.VOTW4-2013> (accessed 27 February 2020).
- Global Wind Atlas (2019)**, “Global Wind Atlas 3.0 map of wind power density at 100m dataset”, <https://globalwindatlas.info/downloads/gis-files> (accessed 14 December 2019).
- GlobalData (2019)**, “Power plants”, <https://power.globaldata.com/PowerPlants/PowerPlantsGrid> (accessed October 2019).
- Grieser, B. et al. (2015)**, “Economics of small wind turbines in urban settings: An empirical investigation for Germany”, *Renewable Energy*, Vol. 78 (June), Elsevier, Amsterdam, pp. 334–350.
- Groissböck, M. (2019)**, “Are open source energy system optimization tools mature enough for serious use?” *Renewable and Sustainable Energy Reviews*, Vol. 102 (March), Elsevier, Amsterdam, pp. 234–248.
- Güneralp, B. et al. (2017)**, “Global scenarios of urban density and its impacts on building energy use through 2050”, *Proceedings of the National Academy of Sciences*, Vol. 114/34, US National Academy of Sciences, Washington, D.C., pp. 8 945–8 950.
- Güneralp, B., I. Güneralp and Y. Liu (2015)**, “Changing global patterns of urban exposure to flood and drought hazards”, *Global Environmental Change*, Vol. 31 (March), Elsevier, Amsterdam, pp. 217–225.
- Hall, S. and K. Roelich (2016)**, “Business model innovation in electricity supply markets: The role of complex value in the United Kingdom”, *Energy Policy*, Vol. 92 (May), Elsevier, Amsterdam, pp. 286–298.

- Hemis, H. (2017)**, *Integrating energy in urban planning processes—insights from Amsterdam/Zaanstad, Berlin, Paris, Stockholm, Vienna, Warsaw and Zagreb*, Synthesis report of Work Package 4 “Innovative governance solutions for integrative urban energy planning”, Urban Learning, European Commission, Brussels, [www.urbanlearning.eu/fileadmin/user\\_upload/documents/D4-2\\_Synthesis-report\\_upgraded\\_processes\\_final\\_170807.pdf](http://www.urbanlearning.eu/fileadmin/user_upload/documents/D4-2_Synthesis-report_upgraded_processes_final_170807.pdf).
- Henley, J. and A. Giuffrida (13 November 2019)**, “Two people die as Venice floods at highest level in 50 years”, *The Guardian* (UK), [www.theguardian.com/environment/2019/nov/13/waves-in-st-marks-square-as-venice-flooded-highest-tide-in-50-years](http://www.theguardian.com/environment/2019/nov/13/waves-in-st-marks-square-as-venice-flooded-highest-tide-in-50-years).
- Hepburn, C. (2006)**, “Regulation by prices, quantities, or both: An update and review”, *Oxford Review of Economic Policy*, Vol. 22/2, Oxford University Press, Oxford, UK, pp. 226–247.
- Heyzer, N. (2014)**, “Six challenges for the future of our cities”, World Economic Forum, [www.weforum.org/agenda/2014/02/six-challenges-future-cities](http://www.weforum.org/agenda/2014/02/six-challenges-future-cities).
- Hoes, O. et al. (2017)**, “Systematic high-resolution assessment of global hydropower potential”, *PLOS ONE* (8 February), PLOS, San Francisco.
- Hoogwijk, M. and W. Graus (2008)**, *Global potential of renewable energy sources: A literature review*, REN21, Utrecht.
- Hopkins, A.S. et al. (2018)**, *Decarbonization of heating energy use in California buildings*, Synapse Energy Economics, Inc., Cambridge, Massachusetts, [www.synapse-energy.com/sites/default/files/Decarbonization-Heating-CA-Buildings-17-092-1.pdf](http://www.synapse-energy.com/sites/default/files/Decarbonization-Heating-CA-Buildings-17-092-1.pdf).
- Hossain, M.S. et al. (2016)**, “Role of smart grid in renewable energy: An overview”, *Renewable and Sustainable Energy Reviews*, Vol. 60 (July), Elsevier, Amsterdam, pp. 1 168–1 184.
- Hott, A. (31 May 2018)**, “Energy as an engine of Africa’s industrialization”, African Development Bank, <https://blogs.afdb.org/energy-engine-africas-industrialization>.
- Huang, R. et al. (2011)**, “Optimal design of hybrid energy system with PV/wind turbine/storage: A case study”, *2011 IEEE International Conference on Smart Grid Communications (SmartGridComm)*, Brussels, pp. 511–516.
- Huide, F. et al. (2017)**, “A comparative study on three types of solar utilization technologies for buildings: Photovoltaic, solar thermal and hybrid photovoltaic/thermal systems”, *Energy Conversion and Management*, Vol. 140 (May), Elsevier, Amsterdam, pp. 1–13.
- Huppmann, D. et al. (2019)**, “The MESSAGEix Integrated Assessment Model and the ix modeling platform (ixmp): An open framework for integrated and cross-cutting analysis of energy, climate, the environment, and sustainable development”, *Environmental Modelling & Software*, Vol. 112 (February), Elsevier, Amsterdam, pp. 143–156.
- ICLEI (16 November 2016)**, “Why are cities setting 100% renewable energy targets?” CityTalk, ICLEI–Local Governments for Sustainability, <https://talkofthecities.iclei.org/why-are-cities-setting-100-renewable-energy-targets>.
- IDB (6 March 2020)**, “Connecting Latin American and Caribbean cities for sustainable urban development”, Inter-American Development Bank, Washington, D.C., [www.idb.org/en/urban-development-and-housing/idb-cities-network](http://www.idb.org/en/urban-development-and-housing/idb-cities-network).
- IEA (2018)**, *The future of cooling: Opportunities for energy-efficient air conditioning*, International Energy Agency, Paris.
- IEA (2008)**, *Particulate emissions from biomass combustion in IEA countries*, International Energy Agency, Paris.
- IEA Task 55 (2019)**, *Solar heat for cities: The sustainable solution for district heating*, International Energy Agency Task 55, International Energy Agency, Paris, <http://task55.iea-shc.org/Data/Sites/1/publications/Solar-Heat-for-Cities--The-Sustainable-Solution-for-District-Heating.pdf>.

- IIASA (2018)**, “MESSAGE-basin Model applied to Indus”, International Institute for Applied Systems Analysis, Laxenburg, [https://iiasa.ac.at/web/home/research/iswel/4\\_MESSAGE\\_Basin\\_Model\\_Applied\\_to\\_Indus\\_-\\_Adriano\\_Vinca\\_-\\_IIA.pdf](https://iiasa.ac.at/web/home/research/iswel/4_MESSAGE_Basin_Model_Applied_to_Indus_-_Adriano_Vinca_-_IIA.pdf).
- Ikejamba, E.C.X. et al. (2017)**, “The empirical reality and sustainable management failures of renewable energy projects in Sub-Saharan Africa (part 1 of 2)”, *Renewable Energy*, Vol. 102 (March), Elsevier, Amsterdam, pp. 234–240.
- IMF (2019)**, “GDP per capita, current prices”, International Monetary Fund, [www.imf.org/external/datamapper/NGDPDPC@WEO/AUS/CAN/FRA/DEU/GBR/USA/JPN](http://www.imf.org/external/datamapper/NGDPDPC@WEO/AUS/CAN/FRA/DEU/GBR/USA/JPN).
- IPCC (2019)**, *IPCC special report on the ocean and cryosphere in a changing climate*, Intergovernmental Panel on Climate Change, Geneva, [www.ipcc.ch/srocc/chapter/summary-for-policymakers](http://www.ipcc.ch/srocc/chapter/summary-for-policymakers).
- IRENA (forthcoming a)**, *Renewable energy solutions for cities of the future*, International Renewable Energy Agency, Abu Dhabi.
- IRENA (forthcoming b)**, *Technical guidelines for the development of bankable renewable energy heating and cooling projects*, International Renewable Energy Agency, Abu Dhabi.
- IRENA (forthcoming c)**, *Thermal energy storage in district heating and cooling*, International Renewable Energy Agency, Abu Dhabi.
- IRENA (2020a)**, *Renewable power generation costs in 2019*, International Renewable Energy Agency, Abu Dhabi.
- IRENA (2020b)**, *Global renewables outlook: Energy transformation 2050*, International Renewable Energy Agency, Abu Dhabi.
- IRENA (2020c)**, *Renewable energy capacity statistics 2020*, International Renewable Energy Agency, Abu Dhabi.
- IRENA (2019a)**, *Innovation landscape for a renewable-powered future: Solutions to integrate variable renewables*, International Renewable Energy Agency, Abu Dhabi.
- IRENA (2019b)**, *Innovation landscape brief: Smart charging for electric vehicles*, International Renewable Energy Agency, Abu Dhabi.
- IRENA (2019c)**, *Innovation landscape brief: Aggregators*, International Renewable Energy Agency, Abu Dhabi.
- IRENA (2019d)**, *Global energy transformation: A roadmap to 2050*, International Renewable Energy Agency, Abu Dhabi.
- IRENA (2019e)**, *Renewable energy statistics 2019*, International Renewable Energy Agency, Abu Dhabi.
- IRENA (2019f)**, *Solar simulators: Application to developing cities*, International Renewable Energy Agency, Abu Dhabi.
- IRENA (2019g)**, *Innovation landscape brief: Innovative ancillary services*, International Renewable Energy Agency, Abu Dhabi.
- IRENA (2018)**, *Bioenergy from Finnish forests: Sustainable, efficient and modern use of wood*, International Renewable Energy Agency, Abu Dhabi.
- IRENA (2016)**, *Renewable energy in cities*, International Renewable Energy Agency, Abu Dhabi.
- IRENA (2015a)**, *Renewable energy target setting*, International Renewable Energy Agency, Abu Dhabi.
- IRENA (2015b)**, *Africa 2030: Roadmap for a renewable energy future*, International Renewable Energy Agency, Abu Dhabi.
- IRENA (2015c)**, *Renewable energy zones for the African Clean Energy Corridor*, International Renewable Energy Agency, Abu Dhabi.
- IRENA (2015d)**, *Solar heat for industrial processes*, International Renewable Energy Agency, Abu Dhabi.
- IRENA and IEA-ETSAP (2015)**, *Technology brief: Solar heat for industrial processes*, International Renewable Energy Agency and International Energy Agency Energy Technology Systems Analysis Programme, Abu Dhabi and Paris.

- IRENA, ICLEI and GIZ (2018)**, *Scaling up renewables in cities: Opportunities for municipal governments*, International Renewable Energy Agency, ICLEI-Local Governments for Sustainability and German Agency for International Cooperation (GIZ), Abu Dhabi.
- ISWA (2015)**, *Bottom ash from WTE plants: Metal recovery and utilisation*, International Solid Waste Association, Rotterdam.
- ISWA (2013)**, *Alternative waste conversion technologies*, International Solid Waste Association, Rotterdam.
- Johnson, N. et al. (2017)**, “A reduced-form approach for representing the impacts of wind and solar PV deployment on the structure and operation of the electricity system”, *Energy Economics*, Vol. 64 (May), Elsevier, Amsterdam, pp. 651–664.
- Johnson, N. et al. (2011)**, “Modeling distributed premises-based renewables integration using HOMER”, *Grid-Interop 2011*, 5–8 December, Phoenix, Arizona.
- Kadian, R. et al. (2007)**, “Energy-related emissions and mitigation opportunities from the household sector in Delhi”, *Energy Policy*, Vol. 35/12, Elsevier, Amsterdam, pp. 6 195–6 211.
- Kale, R.V. and S.D. Pohekar (2014)**, “Electricity demand and supply scenarios for Maharashtra (India) for 2030: An application of long-range energy alternatives planning”, *Energy Policy*, Vol. 72 (September), Elsevier, Amsterdam, pp. 1–13.
- Keirstead, J. and N. Shad (eds.) (2013)**, “Chapter 2: Conceptualizing urban energy systems”, in *Urban Energy Systems: An Integrated Approach*, Routledge, Abingdon-on-Thames.
- Kumar, R. et al. (2018)**, “A critical review of vertical axis wind turbines for urban applications”, *Renewable and Sustainable Energy Reviews*, Vol. 89 (June), Elsevier, Amsterdam, pp. 281–291.
- Kumar, Y.V. and R. Bhimasingu (2014)**, “Optimal sizing of microgrid for an urban community building in south India using HOMER”, *2014 IEEE International Conference on Power Electronics, Drives and Energy Systems (PEDES)*, Mumbai, pp. 1–6.
- Lazarus, M. et al. (2011)**, *Getting to zero: A pathway to a carbon neutral Seattle*, prepared for Project Team: Scenario for a Carbon Neutral Seattle, Seattle, Washington.
- Lemonde, M. (28 May 2020)**, “What is the future of small-scale anaerobic digestion?” BiogasWorld, [www.biogasworld.com/news/future-small-scale-anaerobic-digestion](http://www.biogasworld.com/news/future-small-scale-anaerobic-digestion).
- Lim, X. (2017)**, “How heat from the Sun can keep us all cool”, *Nature*, 31 January, Springer Nature, London.
- Limberger, J. et al. (2017)**, “Geothermal energy in deep aquifers: A global assessment of the resource base for direct heat utilization”, *Renewable and Sustainable Energy Reviews*, Vol. 82 (February), Elsevier, Amsterdam, pp. 961–975.
- Lipman, T.E. et al. (2005)**, *An assessment of battery and hydrogen energy storage systems integrated with wind energy resources in California*, University of California at Berkeley, Berkeley, California.
- Liu, S. et al. (2013)**, “Optimal configuration of hybrid solar-wind distributed generation capacity in a grid-connected microgrid”, *2013 IEEE PES Innovative Smart Grid Technologies Conference (ISGT)*, Washington, D.C.
- Lund, J. and A. Toth (2020)**, “Direct utilization of geothermal energy 2020 worldwide review”, *Proceedings World Geothermal Congress 2020*, Reykjavik, Iceland, 26 April–2 May, [www.geothermal-energy.org/pdf/IGAstandard/WGC/2020/01018.pdf](http://www.geothermal-energy.org/pdf/IGAstandard/WGC/2020/01018.pdf).
- Lund, J.W. (2016)**, “Geothermal energy utilization”, in Kaltschmitt, M. et al. (eds.), *Renewable Energy Systems*, Springer, New York, New York.
- Mann, D. et al. (2015)**, *Taking the LEAP in Uganda: Reflections on developing urban energy baseline and futures models for Kasese and Jinja municipalities*, SAMSET, Uganda.
- Marsden, G. and P. Bonsall (2006)**, “Performance targets in transport policy”, *Transport Policy*, Vol. 13/3, Elsevier, Amsterdam, pp. 191–203.

- Martinez, H., K. DeFrancia and A. Schroder (2018)**, *Moving towards 100% renewable energy: Drivers behind city policies and pledges*, 76th Annual Midwest Political Science Association Conference, Chicago.
- Masdar Institute and IRENA (2015)**, *Renewable energy prospects: United Arab Emirates, REmap 2030 analysis*, International Renewable Energy Agency, Abu Dhabi.
- Masson, V. et al. (2014)**. “Adapting cities to climate change: A systemic modelling approach”, *Urban Climate*, Vol. 10 (December), Elsevier, Amsterdam, pp. 407–429.
- Mathiesen, B.V. and K. Hansen (2017)**, *The role of solar thermal in future energy systems: Country cases for Germany, Italy, Austria and Denmark*, Aalborg University, Aalborg.
- Maturi, L. and J. Admi (2018)**, *Building Integrated Photovoltaic (BIPV) in Trentino Alto Adige*, Springer International Publishing, Switzerland.
- Maurer, C. et al. (2017)**, “Progress in building-integrated solar thermal systems”, *Solar Energy*, Vol. 154 (September), Elsevier, Amsterdam, pp. 158–186.
- Mavropoulos, A. et al. (2012)**, *Globalization and waste management. Phase 1: Concepts and facts*, International Solid Waste Association, Vienna.
- Mikus, M., K. Dziedzic and M. Jurczyk (2016)**, “Flue gas cleaning in municipal waste-to-energy plants”, *Infrastructure and Ecology of Rural Areas* (October), Index Copernicus, Warsaw, pp. 1 179–1 193.
- Milios, L. (2013)**, *Municipal waste management in Sweden*, Paper for the European Environment Agency, Brussels.
- Mirakyan, A. and R. De Guio (2015)**, “Chapter 2: Energy infrastructure planning in cities and territories, quality factors of methods for infrastructure planning”, in *Three Domain Modelling and Uncertainty Analysis, Energy Systems*, Springer International Publishing, Switzerland.
- MIT (2015)**, *The future of solar energy*, Massachusetts Institute of Technology, Cambridge, Massachusetts, <http://energy.mit.edu/wp-content/uploads/2015/05/MITEI-The-Future-of-Solar-Energy.pdf>.
- Mohajeri, N. et al. (2016)**, “Effects of urban compactness on solar energy potential”, *Renewable Energy*, Vol. 93 (August), Elsevier, Amsterdam, pp. 469–482.
- Moya, D., C. Aldas and P. Kaparaju (2018)**, “Geothermal energy: Power plant technology and direct heat applications”, *Renewable and Sustainable Energy Reviews*, Vol. 94 (October), Elsevier, Amsterdam, pp. 889–901.
- Nagao, T. and S. Uyeda (1995)**, “Heat-flow distribution in Southeast Asia with consideration of volcanic heat”, *Tectonophysics*, Vol. 251/1–4, Elsevier, Amsterdam, pp. 153–159.
- Nagy, Z. et al. (2016)**, “The adaptive solar facade: From concept to prototypes”, *Frontiers of Architectural Research*, Vol. 5/2, Elsevier, Amsterdam, pp. 143–156.
- NASA (2019)**, “Global temperature”, US National Aeronautics and Space Administration, <https://climate.nasa.gov/vital-signs/global-temperature>.
- Nastasi, B. and U. Di Matteo (2016)**, “Solar energy technologies in Sustainable Energy Action Plans of Italian big cities”, *Energy Procedia*, Vol. 101 (November), Elsevier, Amsterdam, pp. 1 064–1 071.
- NC State University (2018)**, *Energy storage options for North Carolina*, North Carolina State University, Raleigh, North Carolina, <https://energy.ncsu.edu/storage/wp-content/uploads/sites/2/2019/02/NC-Storage-Study-FINAL.pdf>.
- Nuorkivi, A.E. and A-M. Ahonen (2013)**, “Urban planners with renewable energy skills”, *TeMA – Journal of Land Use, Mobility and Environment*, Vol. 6/2, University of Naples, Naples, pp. 159–170.
- Nussbaumer, T. (2010)**, *Overview on technologies for biomass combustion and emission levels of particulate matter*, prepared for Swiss Federal Office for the Environment, Geneva, <https://pdfs.semanticscholar.org/4f8a/bc2e42c41d1a2be4c18f68af8972ff404712.pdf>.
- OECD (2009)**, *Competitive cities and climate change*, Kamal-Chaoui, L., Robert, A. (eds.), Regional Development Working Papers No. 2, Organisation for Economic Co-operation and Development, Paris, [www.oecd.org/cfe/regional-policy/44232251.pdf](http://www.oecd.org/cfe/regional-policy/44232251.pdf).

- Okereke, O.C. (2017)**, “Causes of failure and abandonment of projects and project deliverables in Africa”, *PM World Journal*, Vol. 6/1, PM World, Addison, Texas.
- Óskarsdóttir, M.Ó. (2014)**, *A general description and comparison of horizontal axis wind turbines and vertical axis wind turbines*, MSc Thesis, School of Engineering and Natural Sciences, Faculty of Industrial Engineering, Mechanical Engineering and Computer Science, Reykjavik, Iceland.
- Pauschinger, T. (2016)**, “Solar thermal energy for district heating”, in Wiltshire, R. (ed.), *Advanced District Heating and Cooling (DHC) Systems*, Woodhead Publishing Series in Energy, Elsevier, Amsterdam, pp. 99–120, [www.sciencedirect.com/science/article/pii/B9781782423744000057](http://www.sciencedirect.com/science/article/pii/B9781782423744000057).
- Peng, B. et al. (2015)**, “Urban passenger transport energy saving and emission reduction potential: A case study for Tianjin, China”, *Energy Conversion and Management*, Vol. 102 (September), Elsevier, Amsterdam, pp. 4–16.
- Phurailatpam, C. et al. (2018)**, “Planning and optimization of autonomous DC microgrids for rural and urban applications in India”, *Renewable and Sustainable Energy Reviews*, Vol. 82 (February), Elsevier, Amsterdam, pp. 194–204.
- Porteous, A. (2005)**, “Why energy from waste incineration is an essential component of environmentally responsible waste management”, *Waste Management*, Vol. 25/4, Elsevier, Amsterdam, pp. 451–459.
- Publicover, B. (27 January 2020)**, “Solar is gaining traction in MENA region—but plenty of obstacles remain”, *pv magazine*, [www.pv-magazine.com/2020/01/17/mesia-outlines-past-progress-future-promise-in-sweeping-look-at-solar-across-middle-east-and-north-africa](http://www.pv-magazine.com/2020/01/17/mesia-outlines-past-progress-future-promise-in-sweeping-look-at-solar-across-middle-east-and-north-africa).
- Ramos, A. et al. (2017)**, “Hybrid photovoltaic-thermal solar systems for combined heating, cooling and power provision in the urban environment”, *Energy Conversion and Management*, Vol. 150 (October), Elsevier, Amsterdam, pp. 838–850.
- Reckien, D. et al. (2018)**, “How are cities planning to respond to climate change? Assessment of local climate plans from the 885 cities in the EU-28”, *Journal of Cleaner Production*, Vol. 191 (August), Elsevier, Amsterdam, pp. 207–219.
- REN21 (2019a)**, *Renewables 2019 global status report*, Renewable Energy Policy Network for the 21st Century, Paris.
- REN21 (2019b)**, *Asia and the Pacific renewable energy status report*, Renewable Energy Policy Network for the 21st Century, Paris.
- REN21, ISEP and ICLEI (2012)**, *Global status report on local renewable energy policies*, Renewable Energy Policy Network for the 21st Century, Institute for Sustainable Energy Policies and ICLEI-Local Governments for Sustainability, [www.ren21.net/Portals/0/documents/Resources/REN21\\_Local\\_Renewables\\_Policies\\_2011.pdf](http://www.ren21.net/Portals/0/documents/Resources/REN21_Local_Renewables_Policies_2011.pdf).
- Reynolds, J. et al. (2017)**, “Upscaling energy control from building to districts: Current limitations and future perspectives”, *Sustainable Cities and Society*, Vol. 35 (November), Elsevier, Amsterdam, pp. 816–829.
- Rickwood P., G. Glazebrook and G. Searle (2008)**, “Urban structure and energy—a review”, *Urban Policy Research*, Vol. 26/1, Taylor & Francis, London, pp. 57–81.
- Rodrigues da Costa, M. et al. (2011)**, *Regulation for smart grids*, Eurelectric, Brussels.
- Rogoff, M.J. and F. Screve (2019)**, *Waste-to-Energy: Technologies and Project Implementation* (3rd edition), Elsevier, Amsterdam.
- Rosas-Flores, J.A. et al. (2016)**, “Potential energy saving in urban and rural households of Mexico by use of solar water heaters, using geographical information system”, *Renewable and Sustainable Energy Reviews*, Vol. 53 (January), Elsevier, Amsterdam, pp. 243–252.
- S&P Global Platts (2018)**, *UDI World Electric Power Plants Database (WEPP)* (database), Platts, Washington, D.C.

- Sadhishkumar, S. and T. Balusamy (2014)**, “Performance improvement in solar water heating systems—a review”, *Renewable and Sustainable Energy Reviews*, Vol. 37 (September), Elsevier, Amsterdam, pp. 191–198.
- Saeidi, D. et al. (2013)**, “Aerodynamic design and economical evaluation of site specific small vertical axis wind turbines”, *Applied Energy*, Vol. 101 (January), Elsevier, Amsterdam, pp. 765–775.
- Saheb, Y. et al. (2014)**, *Guidebook: How to develop a Sustainable Energy Action Plan (SEAP) in South Mediterranean Cities*, Science and policy report of the European Union Joint Research Centre, Brussels, <https://e3p.jrc.ec.europa.eu/publications/guidebook-how-develop-sustainable-energy-action-plan-seap-south-mediterranean-cities>.
- Salata, F. et al. (2015)**, “Method for energy optimization with reliability analysis of a trigeneration and teleheating system on urban scale: A case study”, *Energy and Buildings*, Vol. 86 (January), Elsevier, Amsterdam, pp. 118–136.
- Santamouris, S. (2014)**, “On the energy impact of urban heat island and global warming on buildings”, *Energy and Buildings*, Vol. 82 (October), pp. 100–113.
- Scanner, B. (2017)**, “Ground source heat pumps—history, development, current status, and future prospects”, 12th IEA Heat Pump Conference 2017, Rotterdam, <http://hpc2017.org/wp-content/uploads/2017/05/K.2.9.1-Ground-Source-Heat-Pumps-history-development-current-status-and-future-prospects.pdf>.
- Scanner, B. (2005)**, “Shallow geothermal systems”, <https://geothermalcommunities.eu/assets/elearning/6.11.Shallow%20Geothermal%20Systems.pdf>.
- Scarlat, N. et al. (2015)**, “Evaluation of energy potential of municipal solid waste from African urban areas”, *Renewable and Sustainable Energy Reviews*, Vol. 50 (October), Elsevier, Amsterdam, pp. 1 269–1 286.
- SDH (2019)**, “Solar District Heating. The European Union’s Horizon 2020 research and innovation programme under grant agreement No 691624”, [www.solar-district-heating.eu/en/about-sdh](http://www.solar-district-heating.eu/en/about-sdh).
- SEI (2019)**, “LEAP”, Stockholm Environment Institute, <https://leap.sei.org> (accessed 6 March 2019).
- Sierra Club (2019)**, “100% commitments in cities, counties, & states”, [www.sierraclub.org/ready-for-100/commitments](http://www.sierraclub.org/ready-for-100/commitments) (accessed 12 February 2019).
- Sierra Club (2017)**, *Ready for 100%—2017 case study report*, [www.sierraclub.org/files/blog/RF100-Case-Studies-Report-2017.pdf](http://www.sierraclub.org/files/blog/RF100-Case-Studies-Report-2017.pdf).
- Silva, S. et al. (2018)**, “Electricity residential demand elasticities: Urban versus rural areas in Portugal”, *Energy*, Vol. 144 (February), Elsevier, Amsterdam, pp. 627–632.
- Simoës, T. and A. Estanquero (2016)**, “A new methodology for urban wind resource assessment”, *Renewable Energy*, Vol. 89 (April), Elsevier, Amsterdam, pp. 598–605.
- Sioshansi, F. (2019)**, *Consumer, prosumer, prosumager: How service innovations will disrupt the utility business model*, Academic Press, Cambridge, Massachusetts.
- Skalik, L. and I. Skalikova (2019)**, “Long-term global radiation measurements in Denmark and Sweden”, *IOP Conference Series: Materials Science and Engineering*, Vol. 471/10, IOP, Bristol.
- Smart City Sweden (2020a)**, “Dåva cogeneration plants”, <https://smartcitysweden.com/best-practice/216/dava-cogeneration-plants> (accessed 20 May 2020).
- Smart City Sweden (2020b)**, “Gothenburg smart district cooling”, <https://smartcitysweden.com/best-practice/386/gothenburg-smart-district-cooling> (accessed 20 May 2020).
- Stathopoulos, T. et al. (2018)**, “Urban wind energy: Some views on potential and challenges”, *Journal of Wind Engineering & Industrial Aerodynamics*, Vol. 179 (August), Elsevier, Amsterdam, pp. 146–157.
- Stegner, C. et al. (2016)**, “First year of smart metering with a high time resolution—realistic self-sufficiency rates for households with solar batteries”, *Energy Procedia*, Vol. 99 (November), Elsevier, Amsterdam, pp. 360–369.

- SUPSI et al. (2019)**, *Standardization, performance risks and identification of related gaps for a performance-based qualification in BIPV*, lead author: University of Applied Sciences and Arts of Italian Switzerland (SUPSI), contributing authors: Tecnalia Research & Innovation and Scientific and Technical Centre for Building (CSTB), [www.bipvboost.eu](http://www.bipvboost.eu).
- Toja-Silva, F. et al. (2018)**, “A review of computational fluid dynamics (CFD) simulations of the wind flow around buildings for urban wind energy exploitation”, *Journal of Wind Engineering & Industrial Aerodynamics*, Vol. 180 (September), Elsevier, Amsterdam, pp. 66–87.
- Toja-Silva, F. et al. (2013)**, “Urban wind energy exploitation systems: Behaviour under multi directional flow conditions—opportunities and challenges”, *Renewable and Sustainable Energy Reviews*, Vol. 24 (August), Elsevier, Amsterdam, pp. 364–378.
- Tripanagnostopoulos, Y. (2012)**, “Solar thermal system: Components and applications”, in Sayigh, A. (ed.), *Comprehensive Renewable Energy*, Elsevier, Amsterdam.
- Tummala, A. et al. (2016)**, “A review on small scale wind turbines”, *Renewable and Sustainable Energy Reviews*, Vol. 56 (April), Elsevier, Amsterdam, pp. 1 351–1 371.
- UK100 (2019)**, “About UK100”, [www.uk100.org](http://www.uk100.org) (accessed 22 October 2019).
- Umeå Energi (2019)**, “A short introduction to Umeå Energi and Dåva CHP”, [www.unece.org/fileadmin/DAM/timber/meetings/2019/20190603/5th-tos-we-2-xxx-umea-energi-dava.pdf](http://www.unece.org/fileadmin/DAM/timber/meetings/2019/20190603/5th-tos-we-2-xxx-umea-energi-dava.pdf).
- UN DESA (2019)**, *World urbanization prospects: The 2018 revision*, United Nations Department of Economic and Social Affairs, Population Division, New York.
- UN DESA (2018)**, *The world's cities in 2018—data booklet*, United Nations Department of Economic and Social Affairs, Population Division, New York, [www.un.org/en/events/citiesday/assets/pdf/the\\_worlds\\_cities\\_in\\_2018\\_data\\_booklet.pdf](http://www.un.org/en/events/citiesday/assets/pdf/the_worlds_cities_in_2018_data_booklet.pdf).
- UN DESA (2016)**, *The world's cities in 2016—data booklet*, United Nations Department of Economic and Social Affairs, Population Division, New York, [www.un.org/en/development/desa/population/publications/pdf/urbanization/the\\_worlds\\_cities\\_in\\_2016\\_data\\_booklet.pdf](http://www.un.org/en/development/desa/population/publications/pdf/urbanization/the_worlds_cities_in_2016_data_booklet.pdf).
- UN DESA (2015)**, *World urbanization prospects: The 2014 revision*, United Nations Department of Economic and Social Affairs, Population Division, New York, <https://esa.un.org/unpd/wup/publications/files/wup2014-report.pdf>.
- UNDP (2017)**, “Rapid urbanisation: Opportunities and challenges to improve the well-being of societies”, United Nations Development Programme, New York, <http://hdr.undp.org/en/content/rapid-urbanisation-opportunities-and-challenges-improve-well-being-societies>.
- UNECA (2017)**, *Urbanization and industrialization for Africa's transformation*, United Nations Economic Commission for Africa, Addis Ababa, Ethiopia.
- UNEP (2004)**, “Impacts of summer 2003 heat wave in Europe”, Environment Alert Bulletin, United Nations Environment Programme, [www.unisdr.org/files/1145\\_ewheatwave.en.pdf](http://www.unisdr.org/files/1145_ewheatwave.en.pdf).
- UN ESCAP and UN-Habitat (2015)**, *The state of Asian and Pacific cities*, United Nations Economic and Social Commission for Asia and the Pacific and United Nations Human Settlements Programme, Bangkok and Nairobi.
- UN Statistics (2020)**, “City population by sex, city and city type”, UN Data, <http://data.un.org/Data.aspx?d=POP&f=tableCode:240> (accessed 3 March 2020).
- UN-Habitat (2010)**, *Cities for all: Bridging the urban divide*, United Nations Human Settlements Programme, Nairobi.
- UN-Habitat and ICLEI (2009)**, *Sustainable urban energy planning: A handbook for cities and towns in developing countries*, United Nations Human Settlements Programme and ICLEI—Local Governments for Sustainability, Nairobi and Bonn, <https://sustainabledevelopment.un.org/index.php?page=view&type=400&nr=293&menu=1515>.



- UNISDR (2016)**, *United Nations international strategy for disaster reduction. Annual report 2015*, United Nations Office for Disaster Risk Reduction, Geneva, [www.unisdr.org/files/48588\\_unisdrannualreport2015evs.pdf](http://www.unisdr.org/files/48588_unisdrannualreport2015evs.pdf).
- Urban, F. et al. (2007)**, “Modelling energy systems for developing countries”, *Energy Policy*, Vol. 35/6, Elsevier, Amsterdam, pp. 3 473–3 482.
- US Conference of Mayors (2020)**, “Mayors climate protection center”, United States Conference of Mayors, [www.usmayors.org/mayors-climate-protection-center](http://www.usmayors.org/mayors-climate-protection-center) (accessed 8 February 2020).
- US EPA (2018)**, “Energy recovery from the combustion of municipal solid waste (MSW)”, US Environmental Protection Agency, [www.epa.gov/smm/energy-recovery-combustion-municipal-solid-waste-msw#HowWorks](http://www.epa.gov/smm/energy-recovery-combustion-municipal-solid-waste-msw#HowWorks).
- van Leeuwen, R.P. et al. (2015)**, “Upscaling a district heating system based on biogas cogeneration and heat pumps”, *Energy, Sustainability and Society*, Vol. 5, Springer, Berlin, p. 16.
- van Loo, S. and J. Koppejan (eds.) (2002)**, *Biomass: Combustion and Cofiring*, Twente University Press, The Netherlands.
- Vliet, O.V. et al. (2012)**, “Synergies in the Asian energy system: Climate change, energy security, energy access and air pollution”, *Energy Economics*, Vol. 34 (December), Elsevier, Amsterdam, pp. 40–480.
- Wang, Z. et al. (2015)**, “Solar water heating: From theory, application, marketing and research”, *Renewable and Sustainable Energy Reviews*, Vol. 41 (January), Elsevier, Amsterdam, pp. 68–84.
- WBA (2016)**, *The role of bioenergy in European cities*, World Bioenergy Association, Stockholm, [https://worldbioenergy.org/uploads/WBA%20Report\\_Bioenergy%20in%20European%20Cities\\_lowres.pdf](https://worldbioenergy.org/uploads/WBA%20Report_Bioenergy%20in%20European%20Cities_lowres.pdf).
- We Are Still In (2020)**, “Who’s in”, [www.wearestillin.com/signatories](http://www.wearestillin.com/signatories) (accessed March 2020).
- Weiss, W. and M. Rommel (2008)**, *Process heat collectors*, AEE–Institute for Sustainable Technologies and Fraunhofer Institute for Solar Energy Systems, Gleisdorf, [www.iea-shc.org/data/sites/1/publications/task33-Process\\_Heat\\_Collectors.pdf](http://www.iea-shc.org/data/sites/1/publications/task33-Process_Heat_Collectors.pdf).
- Weiss, W. and M. Spörk-Dür (2019)**, *Solar heat worldwide: Global market development and trends in 2019*, International Energy Agency Solar Heating & Cooling Programme, Paris, [www.iea-shc.org/Data/Sites/1/publications/Solar-Heat-Worldwide-2020.pdf](http://www.iea-shc.org/Data/Sites/1/publications/Solar-Heat-Worldwide-2020.pdf).
- Werner, S. (2017)**, “International review of district heating and cooling”, *Energy*, Vol. 137 (October), Elsevier, Amsterdam, pp. 617–631.
- WHO (2018)**, *WHO Global Ambient Air Quality Database* (database), World Health Organization, Geneva, [www.who.int/airpollution/data/cities/en](http://www.who.int/airpollution/data/cities/en).
- World Bank (2017)**, “Population growth (annual %)”, <https://data.worldbank.org/indicator/SP.POP.GROW>.
- Yang, A-S. et al. (2016)**, “Estimation of wind power generation in dense urban area”, *Applied Energy*, Vol. 171 (June), Elsevier, Amsterdam, pp. 213–230.
- Yu, H. et al. (2015)**, “Urban energy consumption and CO<sub>2</sub> emissions in Beijing: Current and future”, *Energy Efficiency*, Vol. 8/3, Springer, Berlin, pp. 527–543.
- Zanon B. and S. Verones (2013)**, “Climate change, urban energy and planning practices: Italian experiences of innovation in land management tools”, *Land Use Policy*, Vol. 32 (May), Elsevier, Amsterdam, pp. 343–355.
- Zhang, L. et al. (2011)**, “Alternative scenarios for the development of a low-carbon city: A case study of Beijing, China”, *Energies*, Vol. 4/12, MDPI, Basel, pp. 2 295–2 310.
- Zhou, K. et al. (2016)**, “Big data driven smart energy management: From big data to big insights”, *Renewable and Sustainable Energy Reviews*, Vol. 56 (April), Elsevier, Amsterdam, pp. 215–225.
- Zscheischler, J. and S. Seneviratne (2017)**, “Dependence of drivers affects risks associated with compound events”, *Science Advances*, Vol. 3 (June), American Association for the Advancement of Science, Washington, D.C., p. e1700263.

